

QUESTO E' UN DISEGNO REALIZZATO AL CAD NON MODIFICARE	
FIRMA	DATA
DISEGN.	
CONTR.	
VISTO	
VISTO A.Q.	

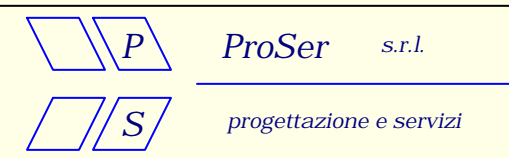

TITOLO		
UGBC - Schema a Blocchi		
FORMATO	CODICE	REV
A4		
PROTEL Adv. Sch. Cap Foglio di		

A

A

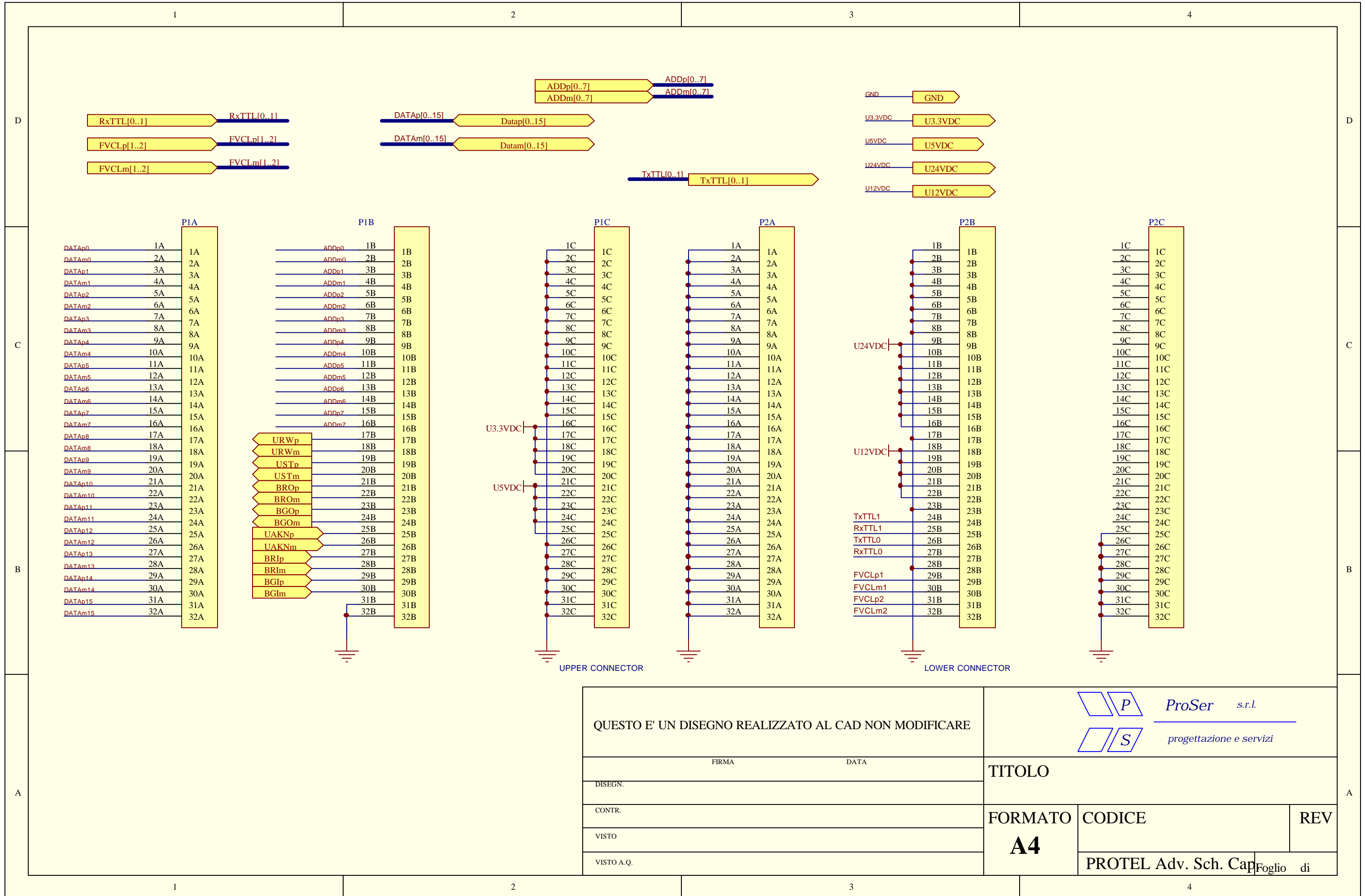

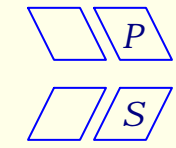
QUESTO E' UN DISEGNO REALIZZATO AL CAD NON MODIFICARE		 ProSer s.r.l. progettazione e servizi	
FIRMA _____ DATA _____		TITOLO _____	
DISEGN. _____	FORMATO A4		CODICE _____
CONTR. _____	VISTO _____		REV _____
VISTO A.Q. _____	PROTEL Adv. Sch. Cap _____		Foglio di _____

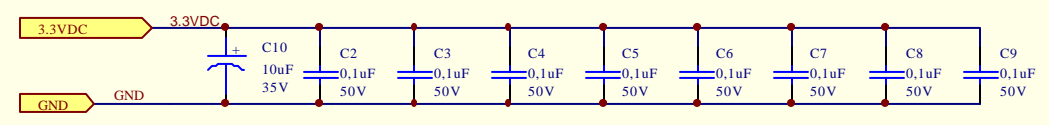
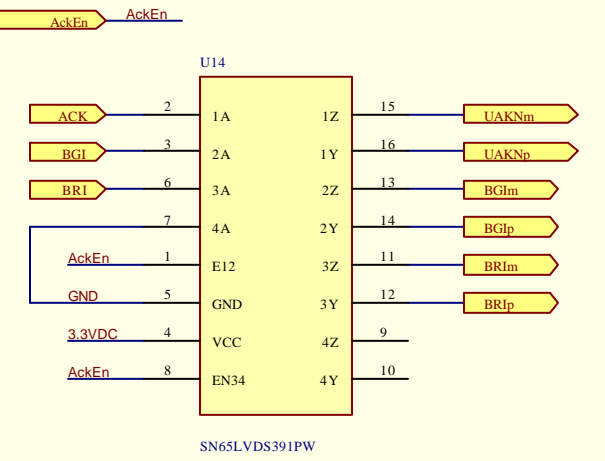
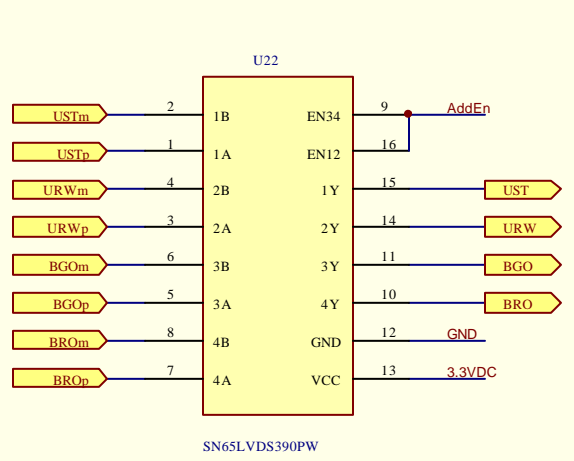
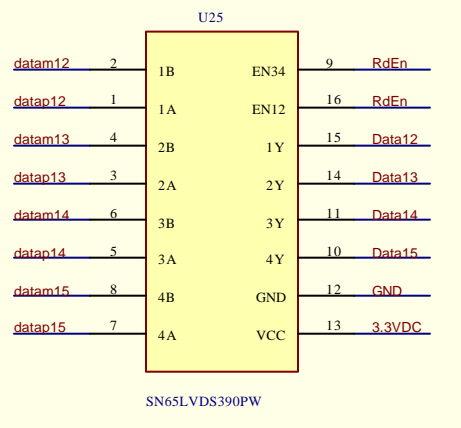
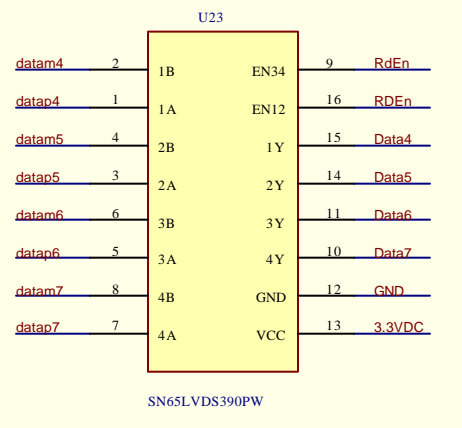
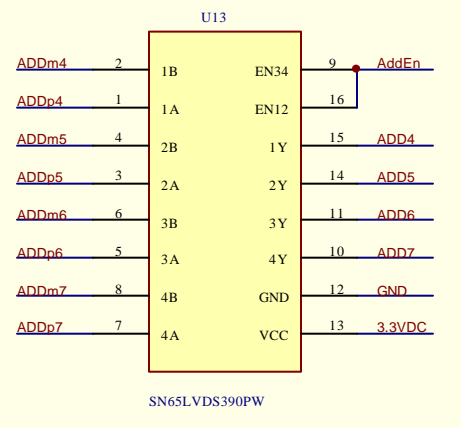
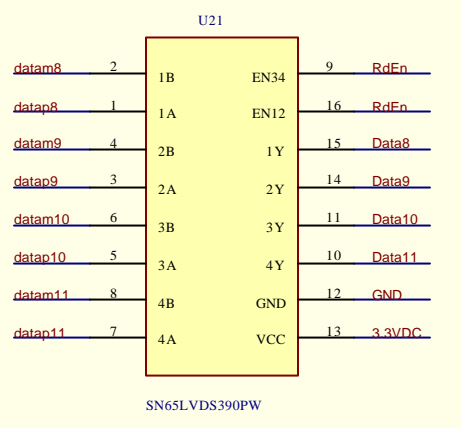
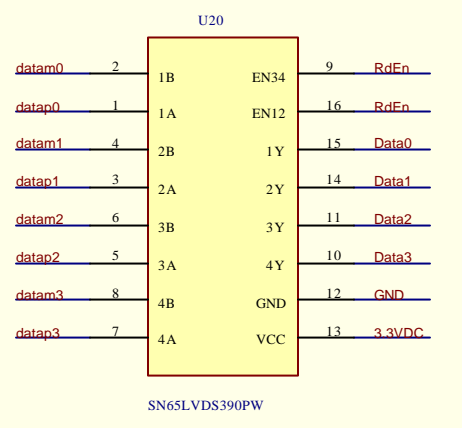
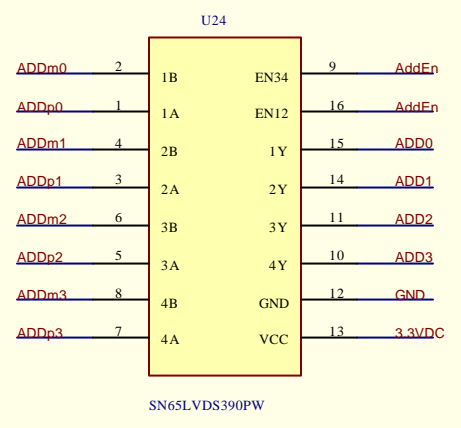
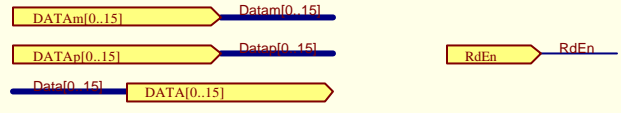
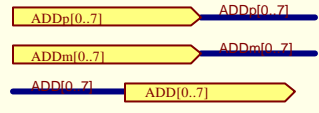

QUESTO E' UN DISEGNO REALIZZATO AL CAD NON		 ProSer s.r.l. progettazione e servizi
PRODOTTO	DATA	
TITOLO	UGBC - IO-IN	
FORMATO	CODICE	REV
A3	PROTEL Adv. Sch. Cd	Foglio di

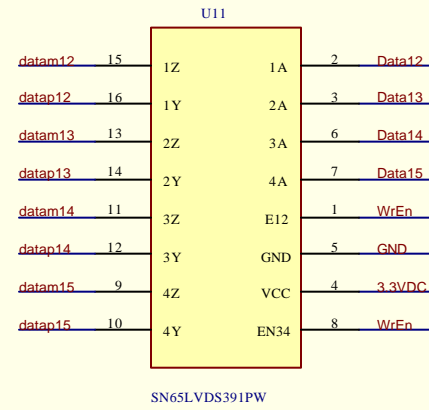
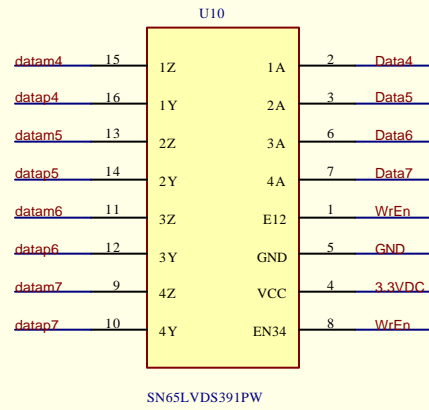
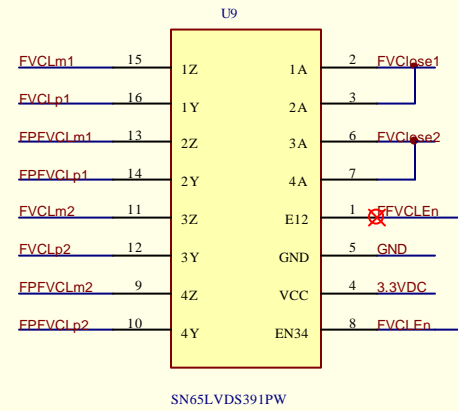
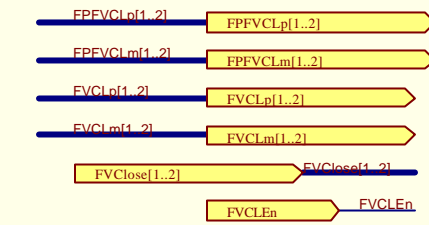
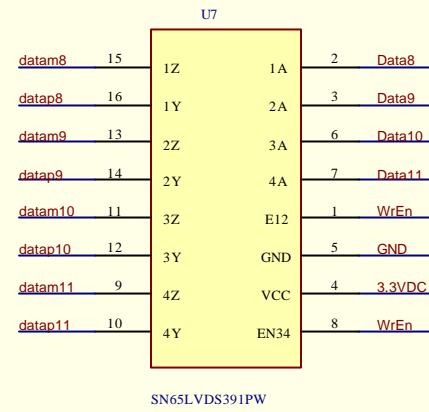
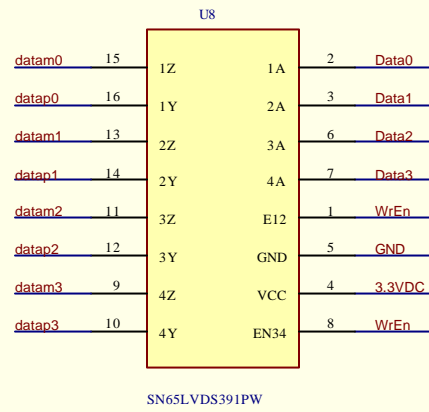
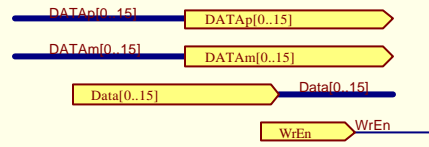

UGBC - IO-OUT

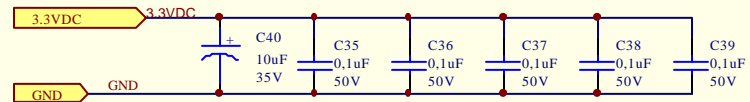

QUESTO E' UN DISEGNO REALIZZATO AL CAD NON		 ProSer s.r.l. progettazione e servizi
PRODOTTO	DATA	
TITOLO		UGBC - IO-OUT
FORMATO	CODICE	REV
A3		PROTEL Adv. Sch. Cd Foglio di

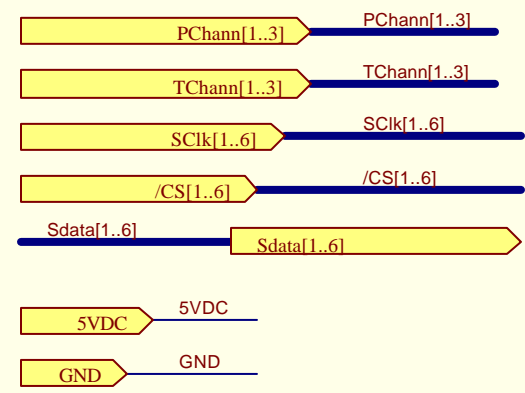
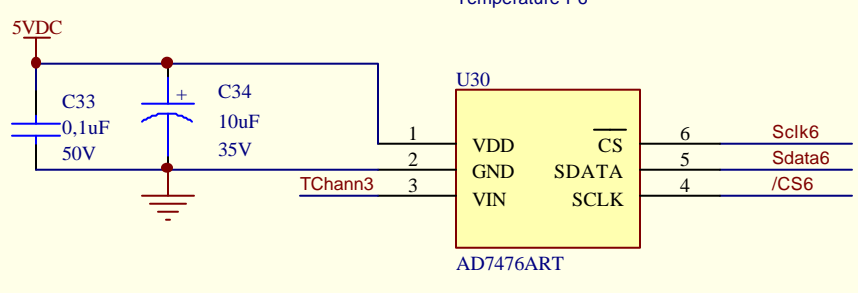
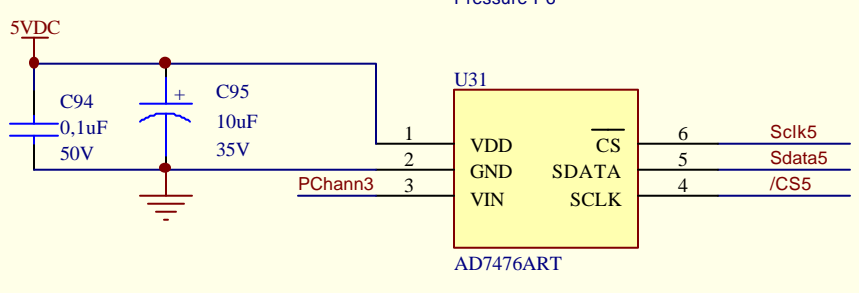
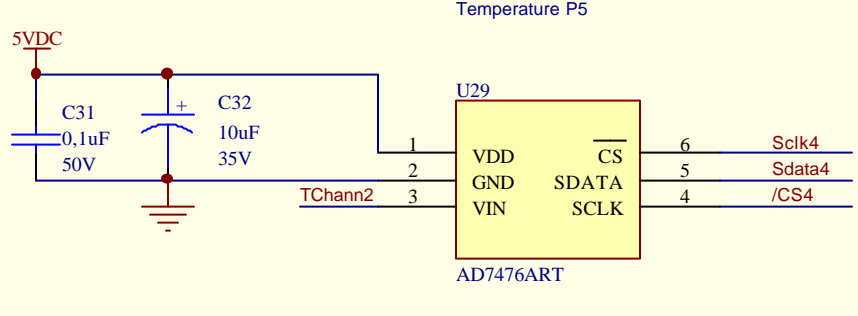
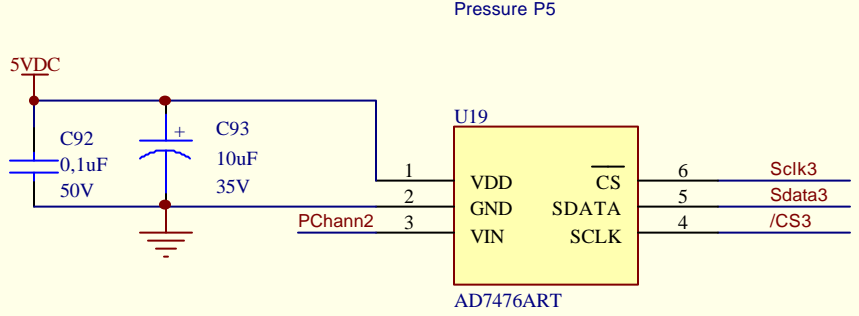
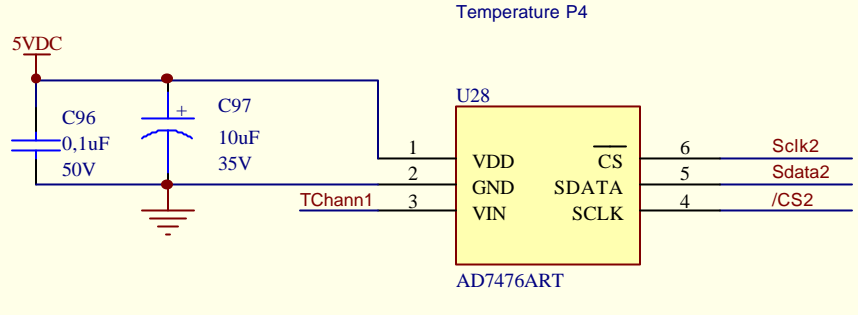
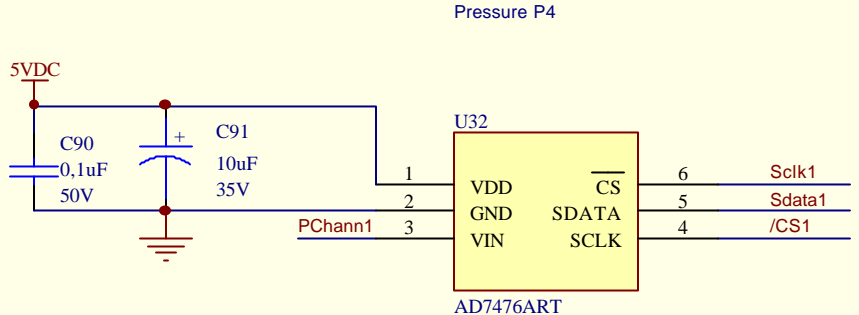

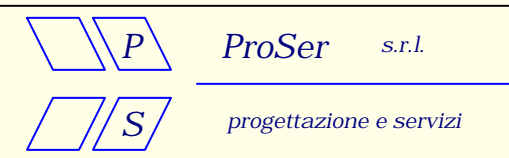

QUESTO E' UN DISEGNO REALIZZATO AL CAD NON MODIFICARE

FIRMA	DATA
DISEGN.	
CONTR.	
VISTO	
VISTO A.Q.	

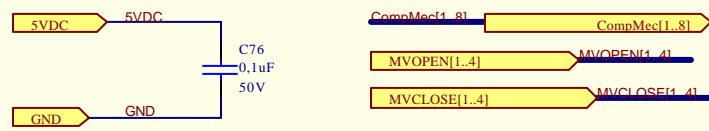
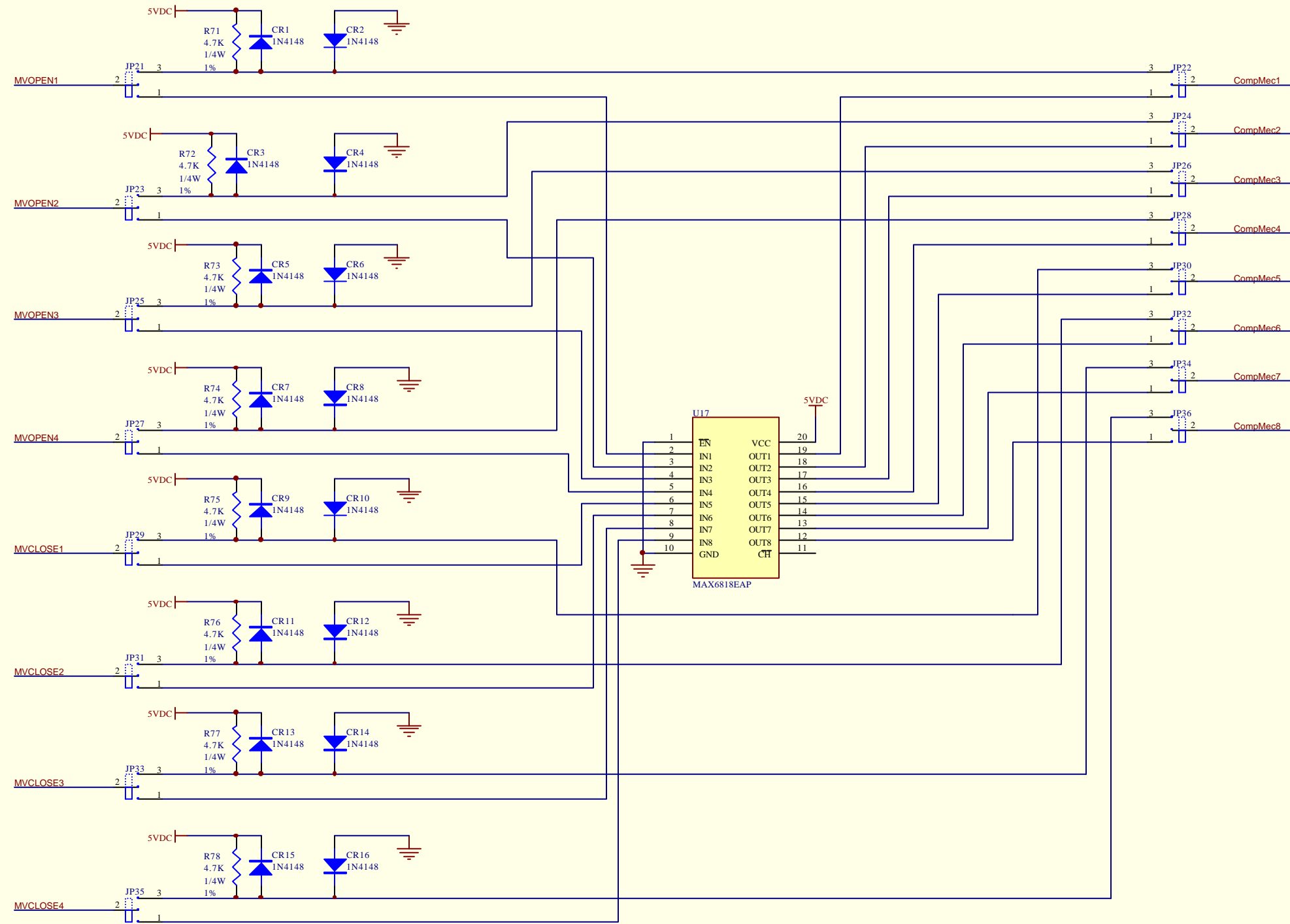

TITOLO		UGBC - AD-6	
FORMATO	CODICE	REV	
A4			
PROTEL Adv. Sch. Cap		Foglio di	



QUESTO E' UN DISEGNO REALIZZATO AL CAD NON		 ProSer s.r.l. progettazione e servizi
PRODOTTO	DATA	
TITOLO		UGBC - Antibouncing
FORMATO	CODICE	REV
A3	PROTEL Adv. Sch. Cad	Foglio di

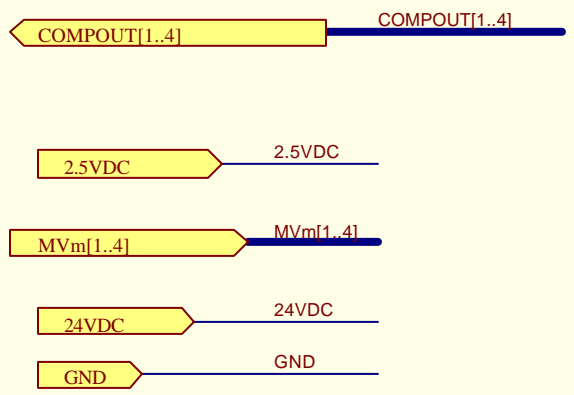
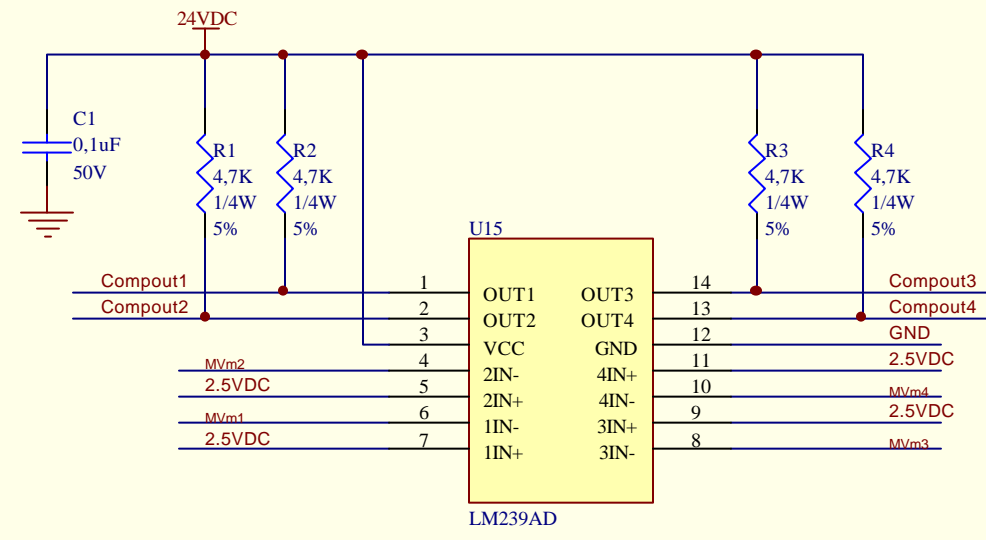

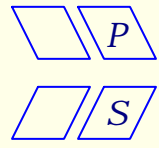
QUESTO E' UN DISEGNO REALIZZATO AL CAD NON MODIFICARE		 ProSer s.r.l. progettazione e servizi	
FIRMA _____ DATA _____		TITOLO _____	
DISEGN. _____	FORMATO A4		
CONTR. _____	CODICE _____		REV _____
VISTO _____	PROTEL Adv. Sch. Cap _____ Foglio di _____		
VISTO A.Q. _____			

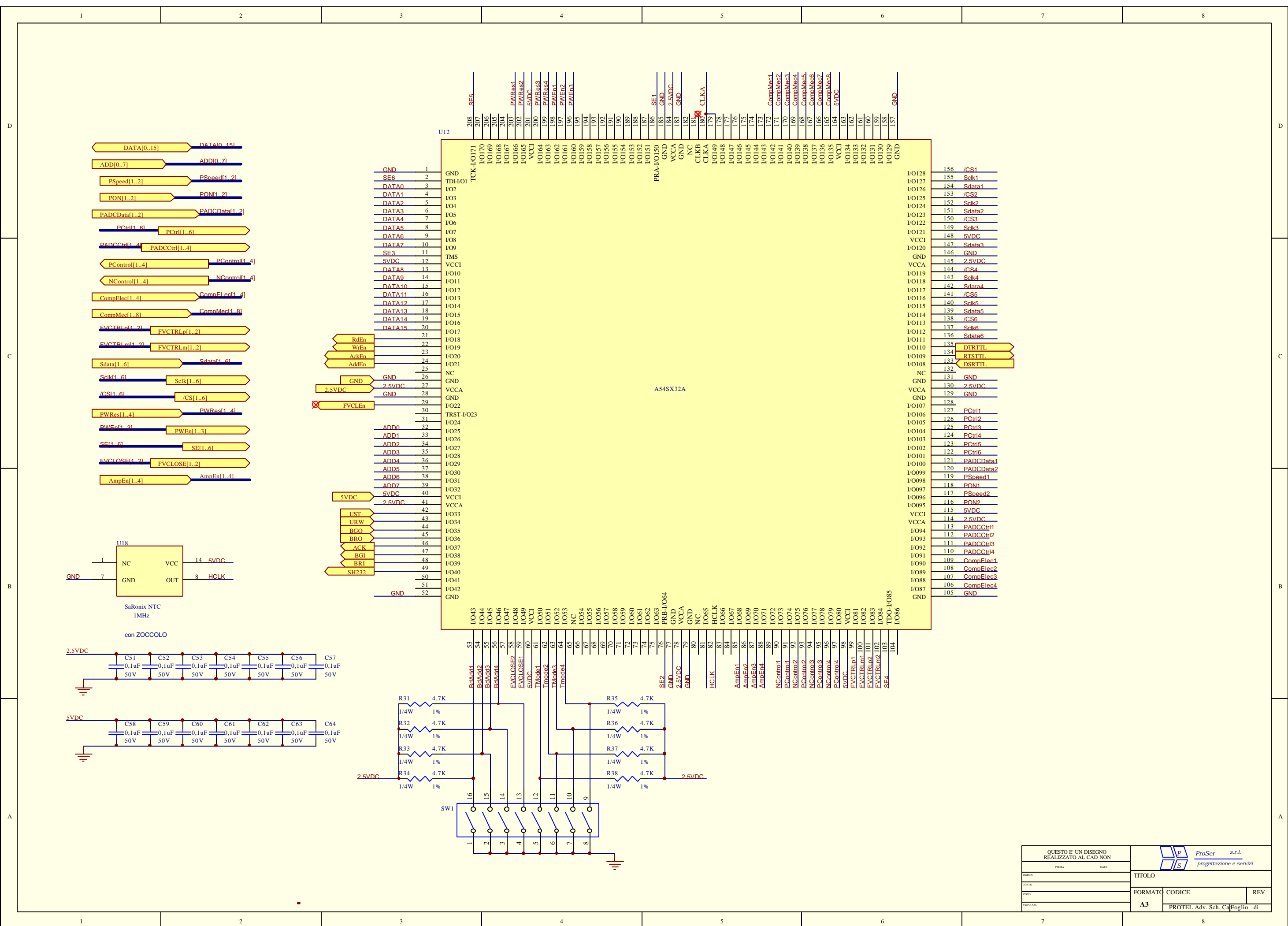

QUESTO E' UN DISEGNO REALIZZATO AL CAD NON		 ProSer s.r.l. progettazione e servizi
PRODOTTO	DATA	
TITOLO		REV
FORMATO	CODICE	
A3	PROTEL Adv. Sch. Cd	Foglio di

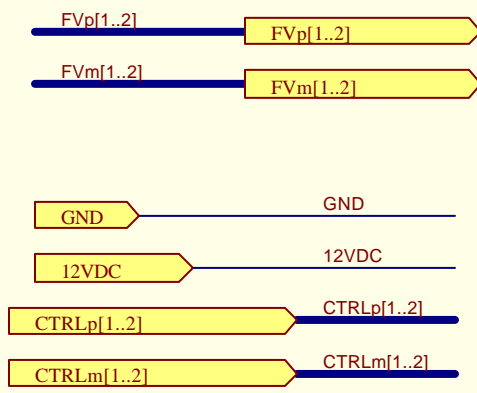
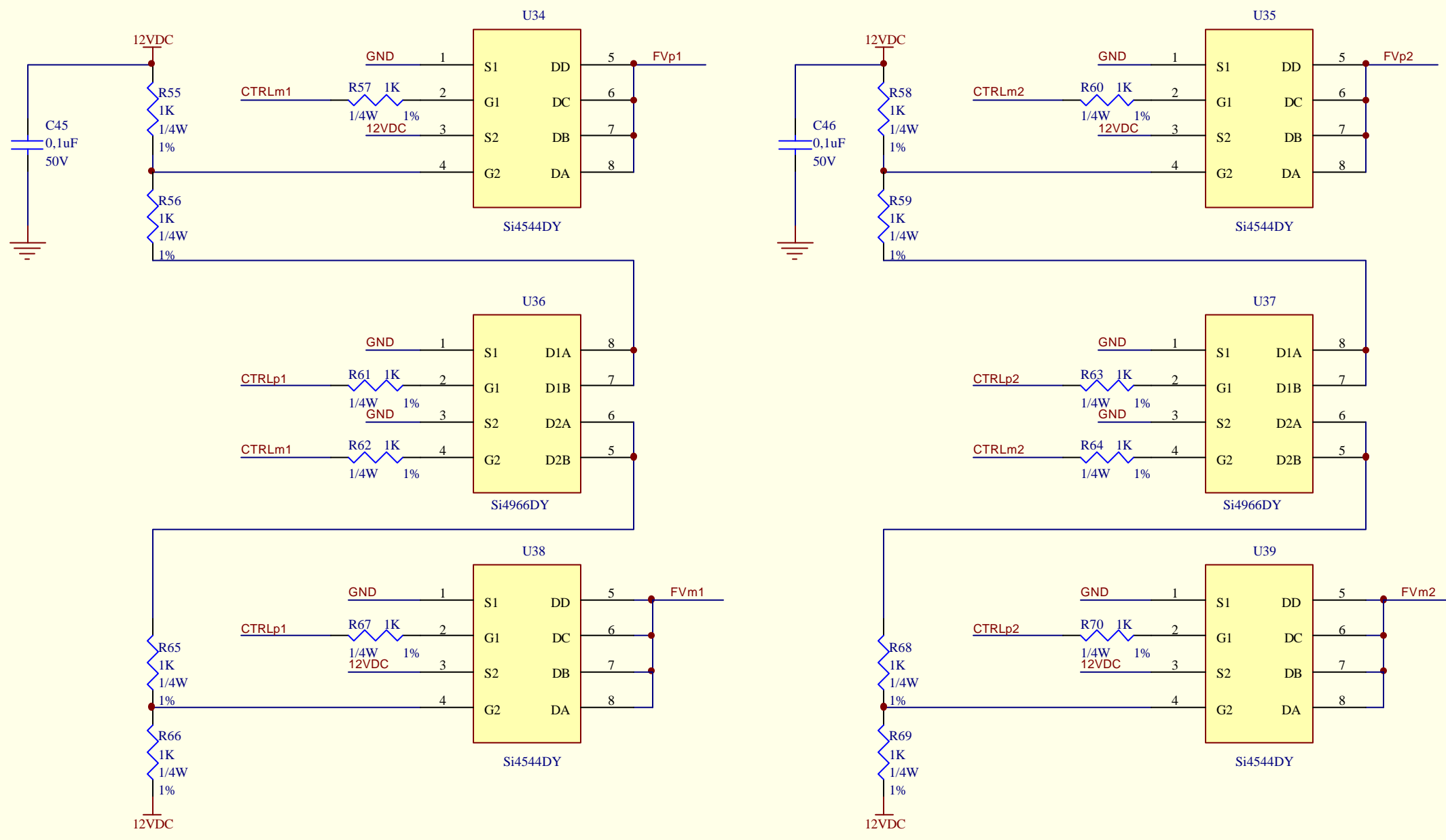

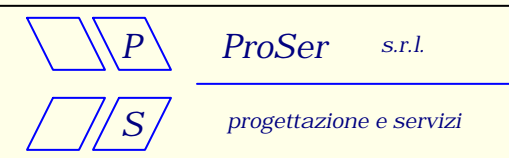

QUESTO E' UN DISEGNO REALIZZATO AL CAD NON MODIFICARE	
FIRMA	DATA
DISEGN.	
CONTR.	
VISTO	
VISTO A.Q.	

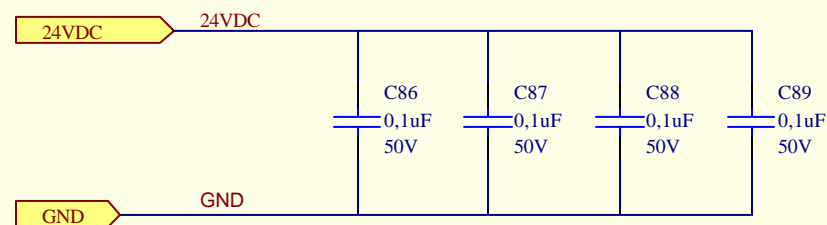
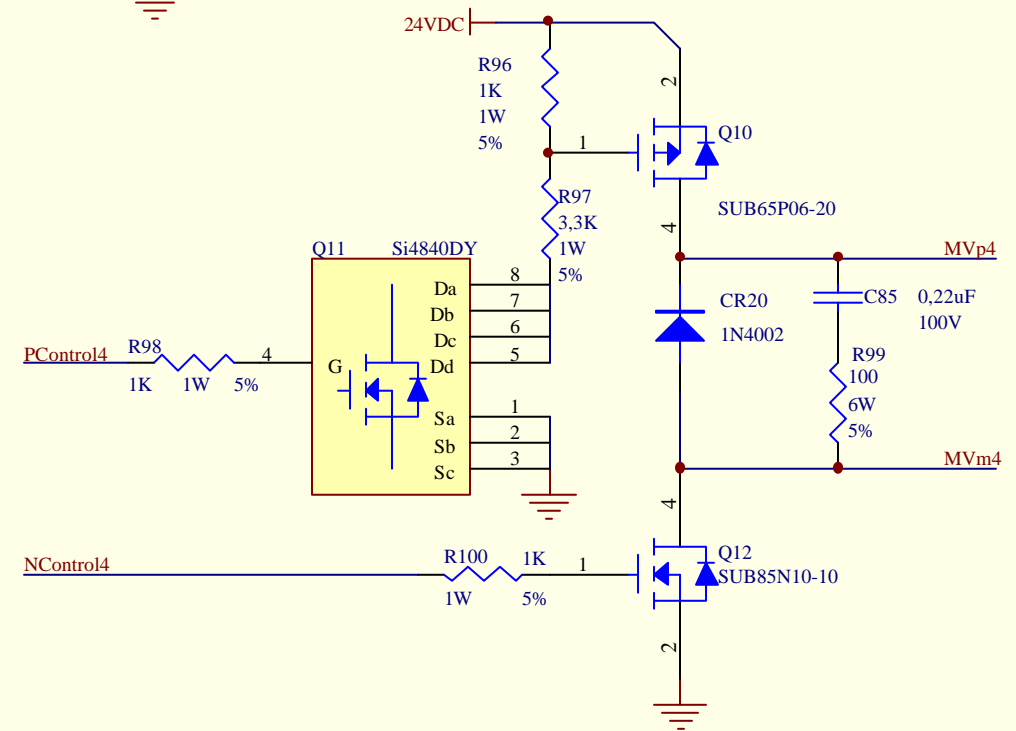
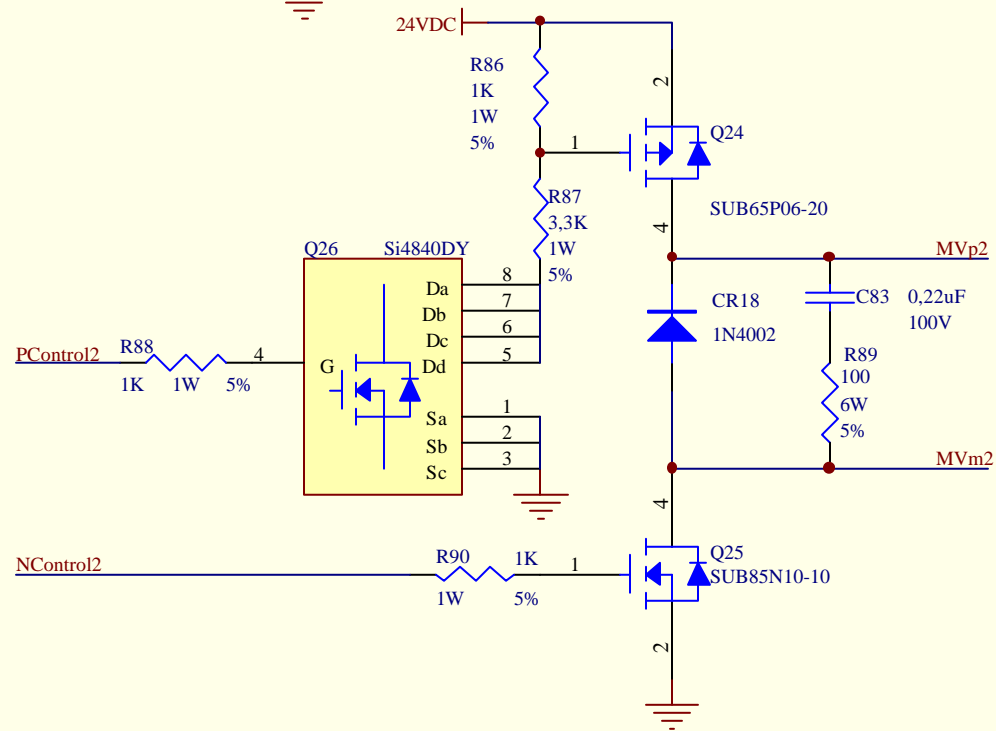
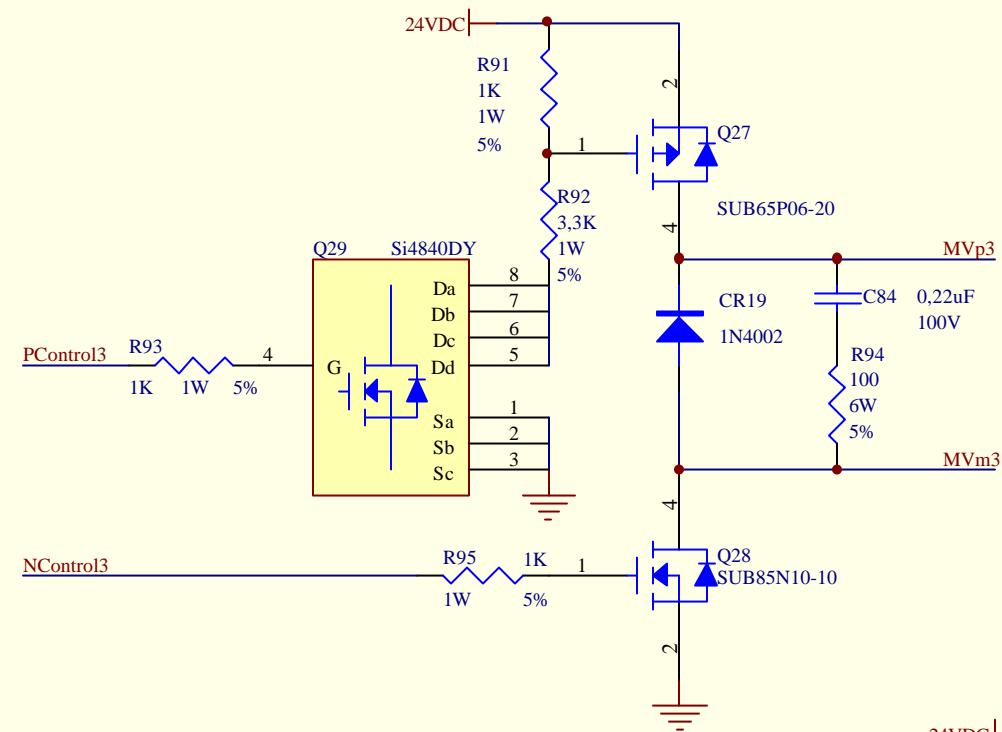
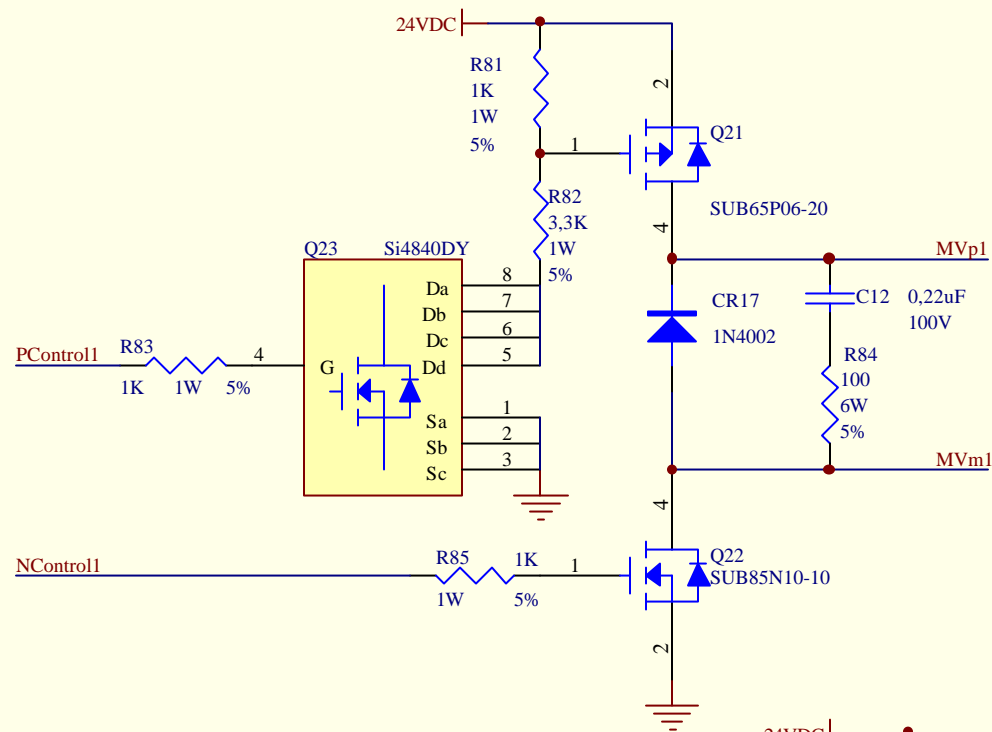

TITOLO		UGBC - FV	
FORMATO	CODICE	REV	
A4			
PROTEL Adv. Sch. Cap Foglio di			



QUESTO E' UN DISEGNO REALIZZATO AL CAD NON MODIFICARE		 ProSer s.r.l.  progettazione e servizi	
FIRMA	DATA	TITOLO	
DISEGN.			
CONTR.		FORMATO	CODICE
VISTO		A4	REV
VISTO A.Q.		PROTEL Adv. Sch. Cap Foglio di	

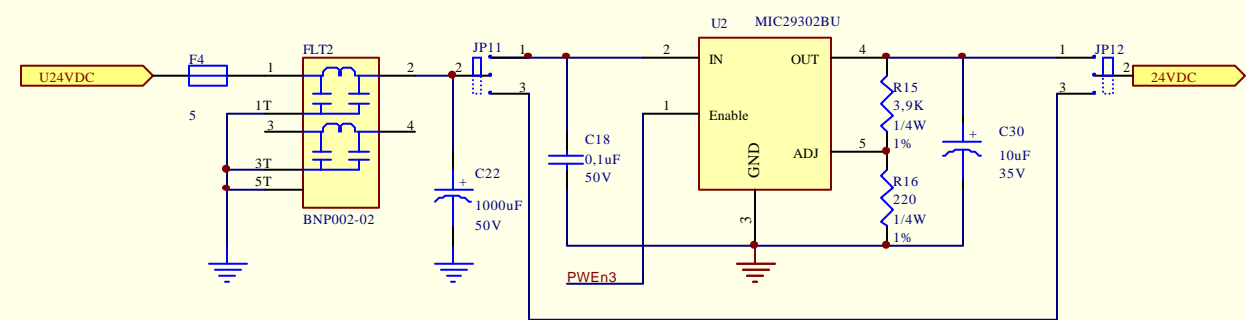
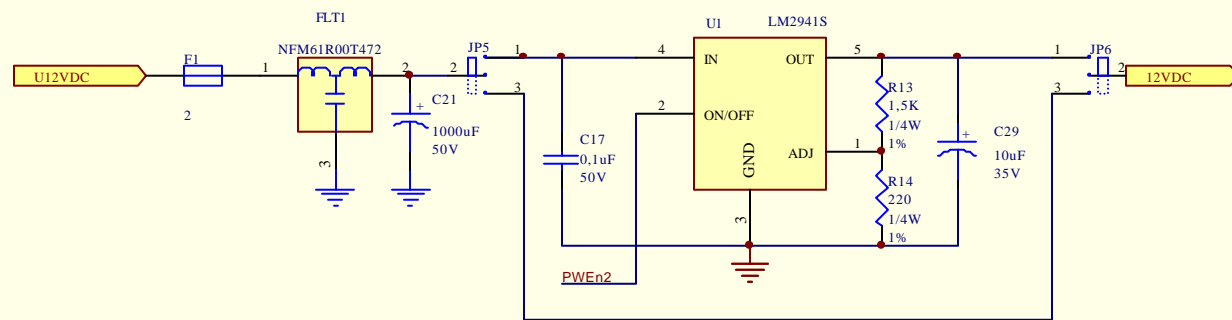
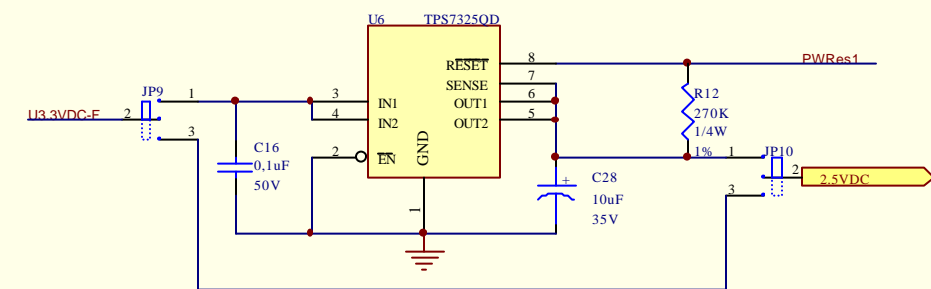
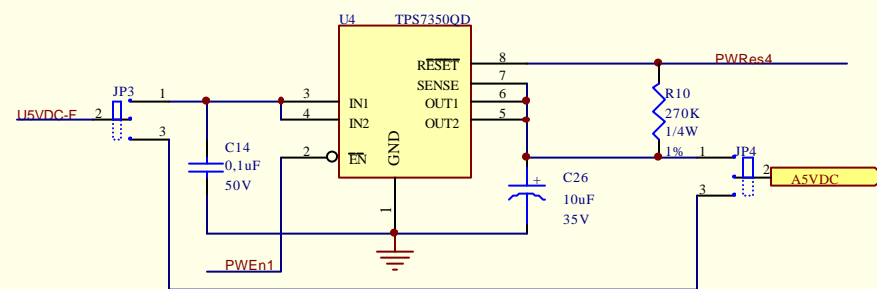
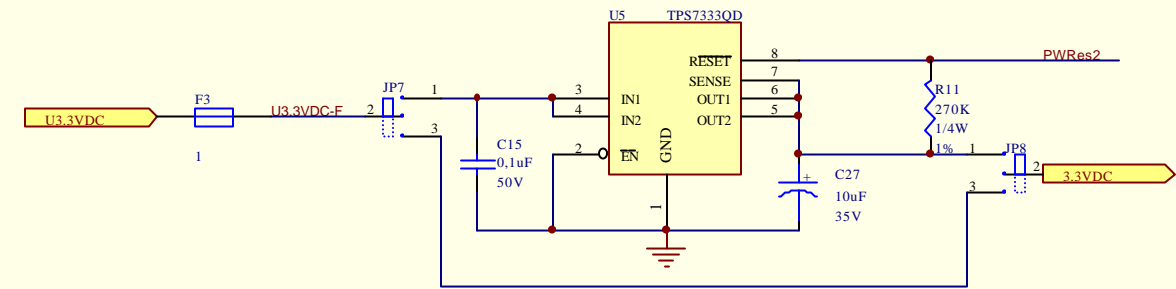
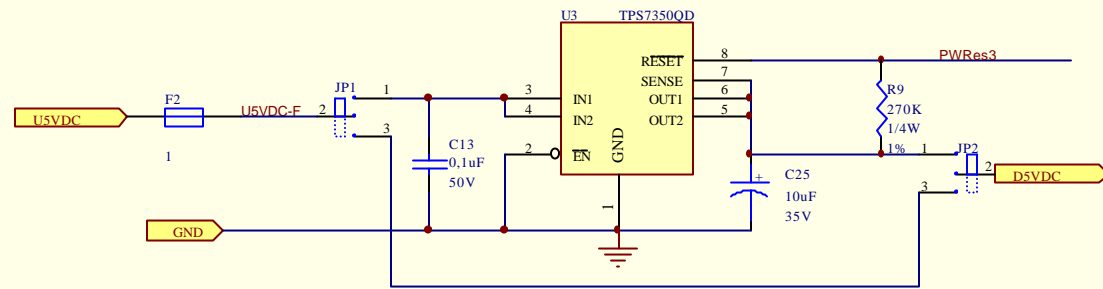

PWRes1_41 PWRes1_41

PWEn1_31 PWEn1_31

UGBC - Power

QUESTO E' UN DISEGNO REALIZZATO AL CAD NON		 ProSer s.r.l. progettazione e servizi
PRODOTTO	DATA	
TITOLO		UGBC - Power
FORMATO	CODICE	REV
A3	PROTEL Adv. Sch. Ca	Foglio di

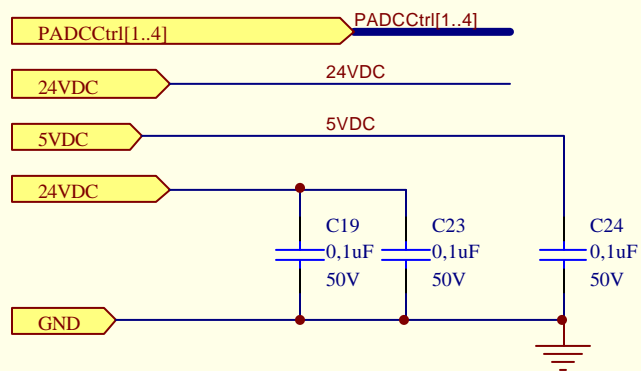
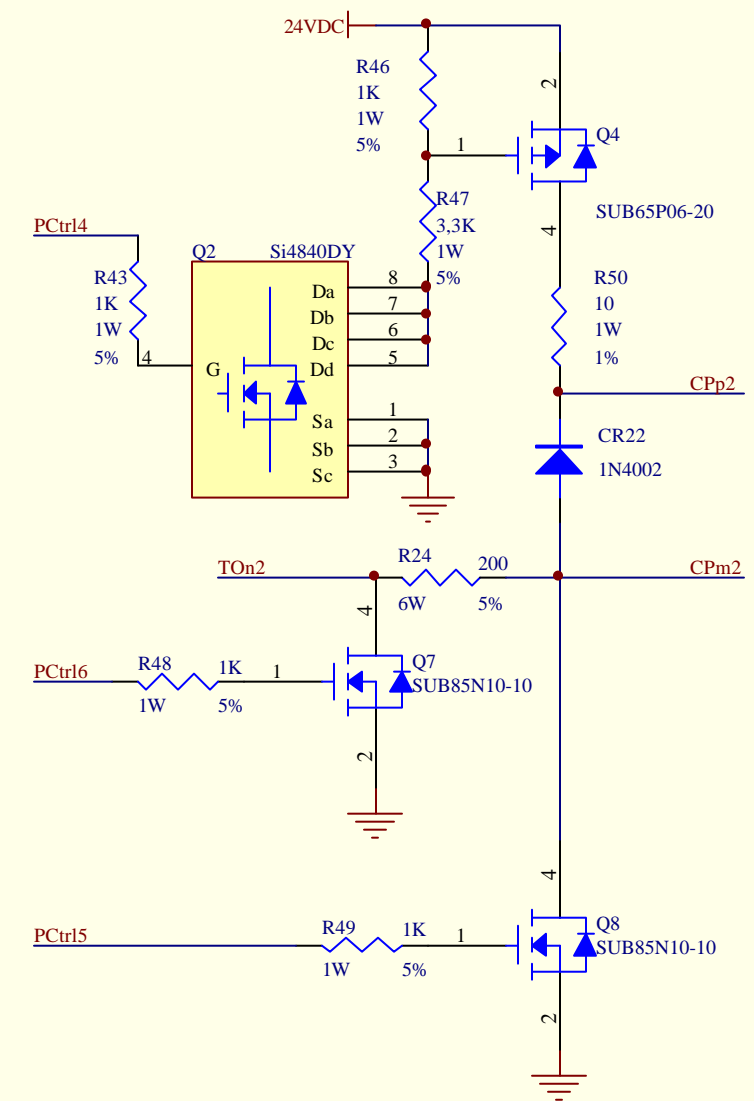
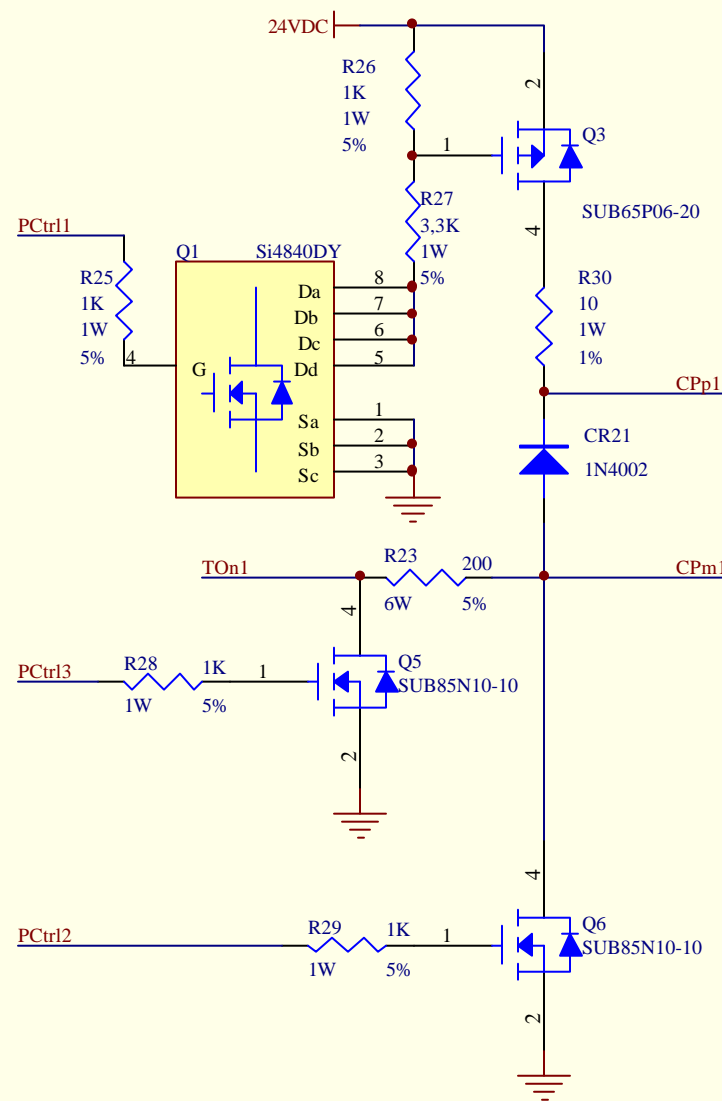
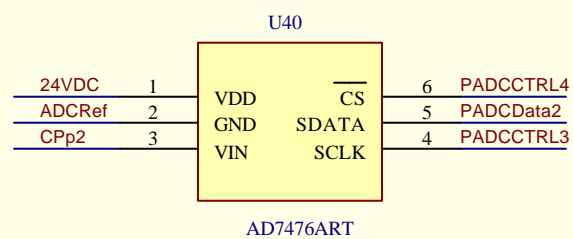
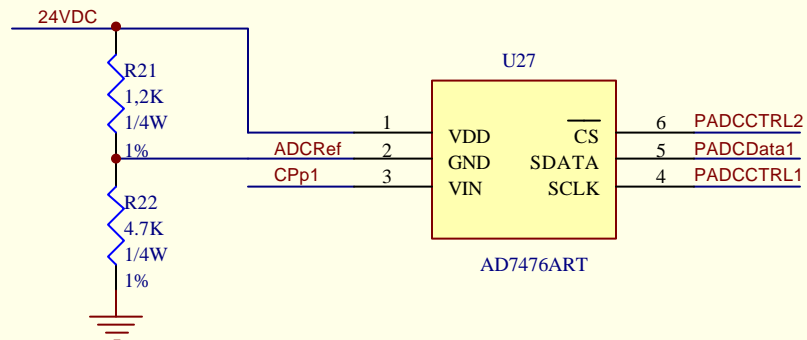
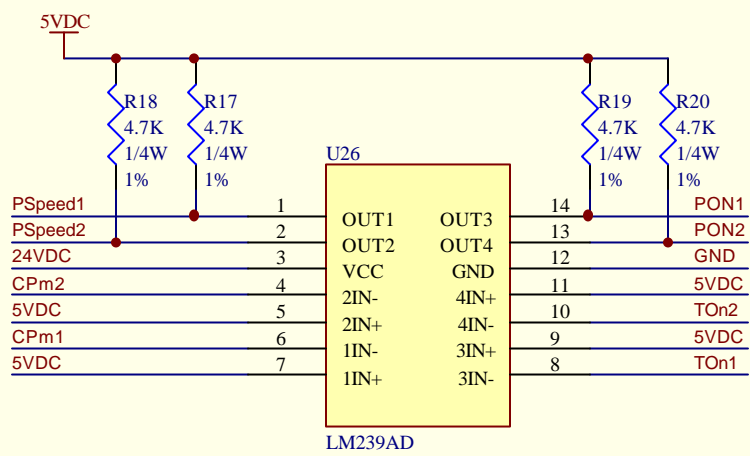



QUESTO E' UN DISEGNO REALIZZATO AL CAD NON MODIFICARE

FIRMA	DATA
DISEGN.	
CONTR.	
VISTO	
VISTO A.Q.	

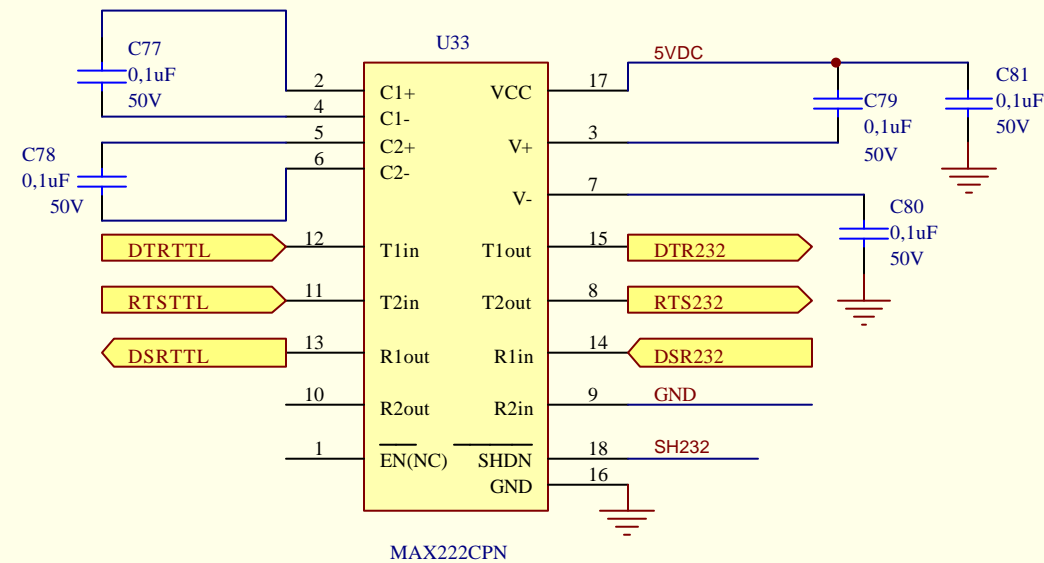
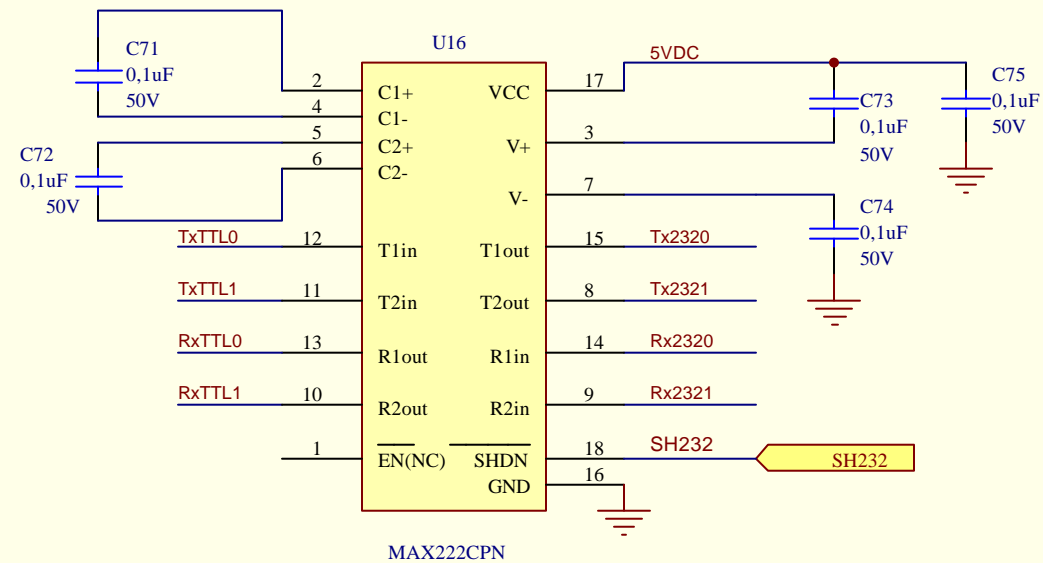
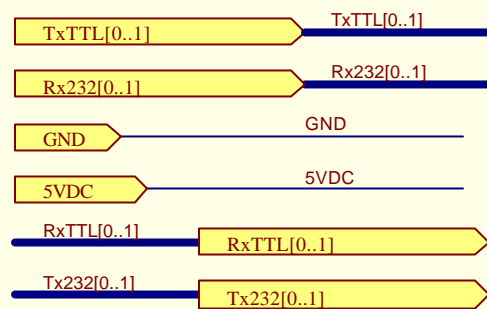
 progettazione e servizi	
UGBC - PUMPCL2	
TITOLO	
FORMATO	CODICE
A4	
REV	
PROTEL Adv. Sch. Cap Foglio di	



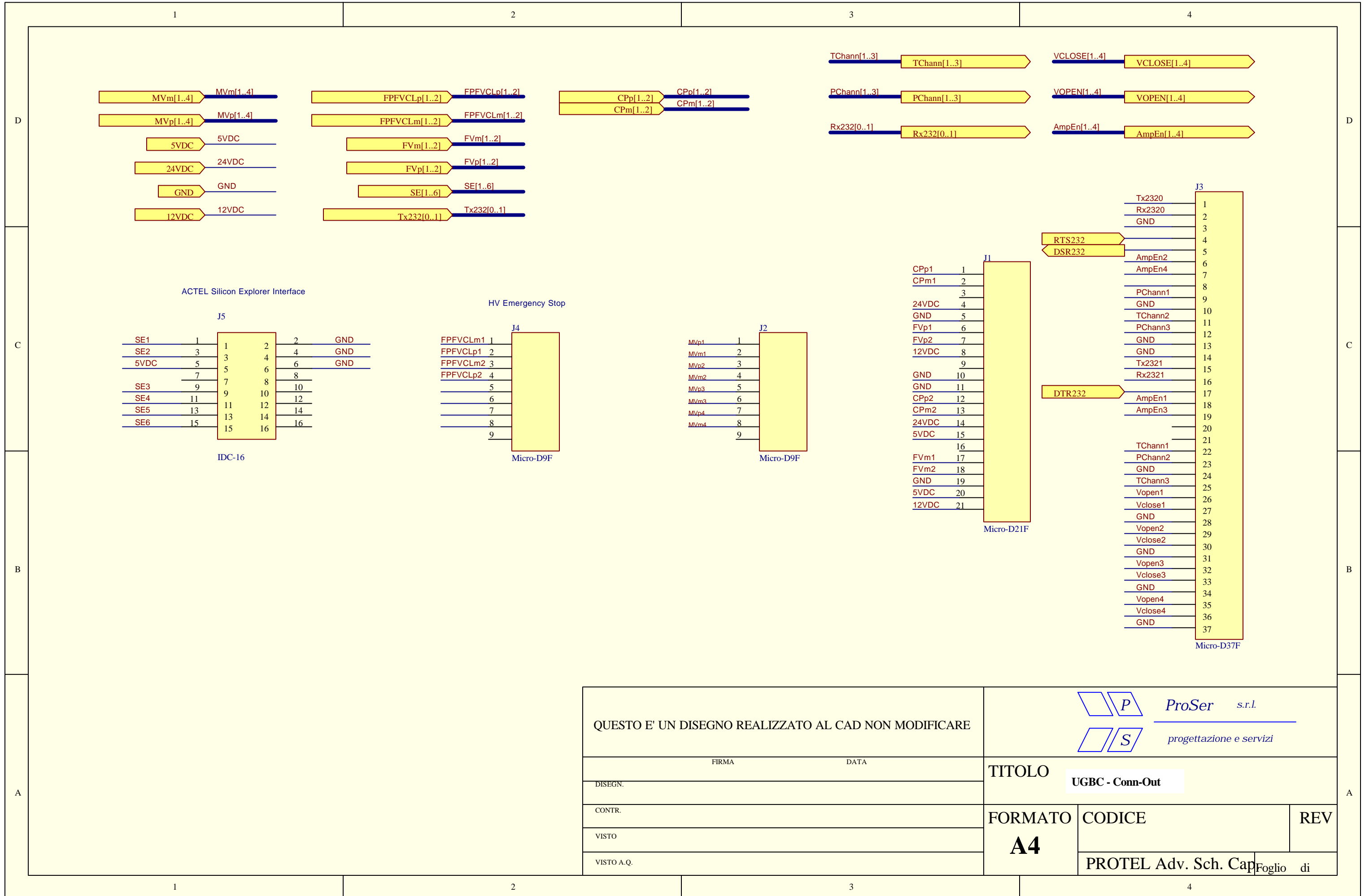

QUESTO E' UN DISEGNO REALIZZATO AL CAD NON MODIFICARE		 ProSer s.r.l.  progettazione e servizi	
FIRMA	DATA	TITOLO	
DISEGN.			
CONTR.	UGBC - RS232	FORMATO	CODICE
VISTO		A4	REV
VISTO A.Q.		PROTEL Adv. Sch. Cap Foglio di	

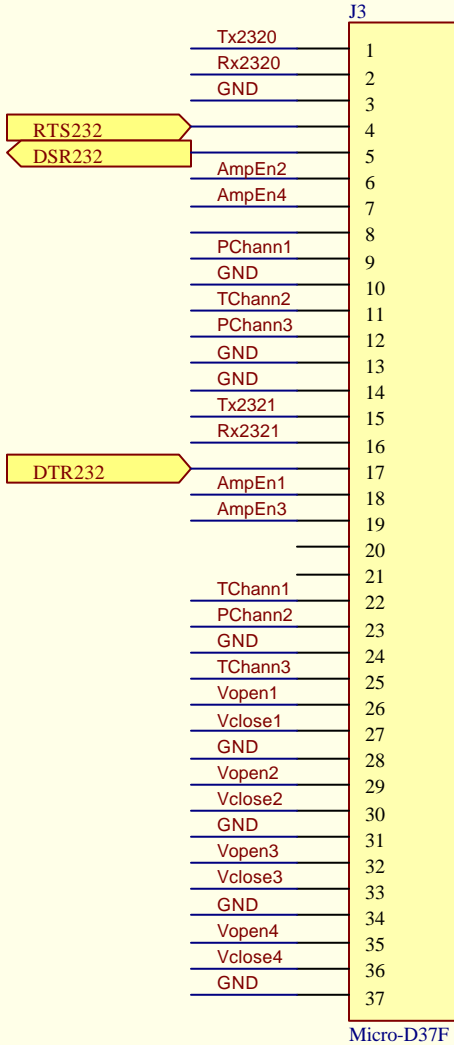
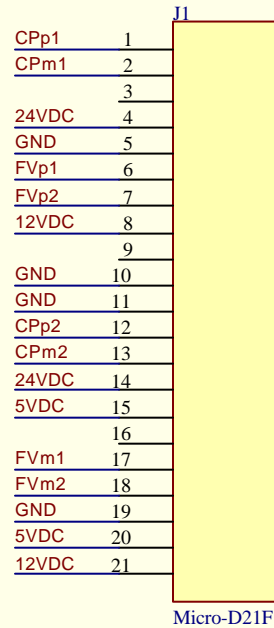
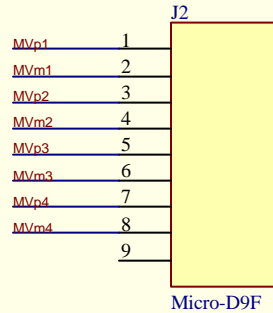
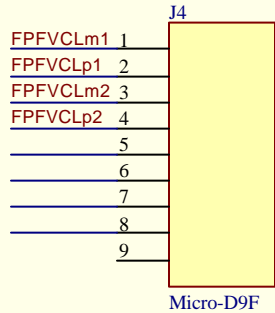
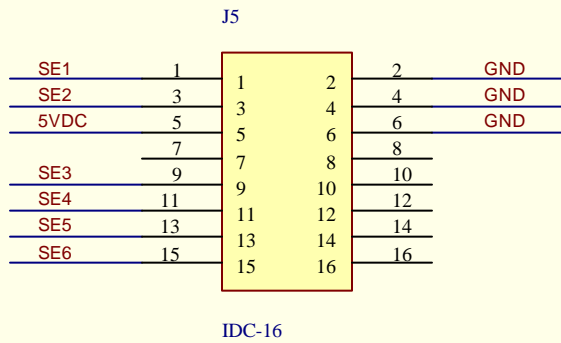

ACTEL Silicon Explorer Interface

HV Emergency Stop

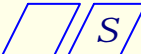

QUESTO E' UN DISEGNO REALIZZATO AL CAD NON MODIFICARE		 ProSer s.r.l.  progettazione e servizi	
FIRMA _____ DATA _____		TITOLO UGBC - Conn-Out	
DISEGN.		FORMATO A4	CODICE _____
CONTR.			
VISTO		REV _____	
VISTO A.Q.		PROTEL Adv. Sch. Cap _____ Foglio di _____	