

QUESTO E' UN DISEGNO REALIZZATO AL CAD NON MODIFICARE

FIRMA	DATA
DISEGN.	
CONTR.	
VISTO	
VISTO A.Q.	

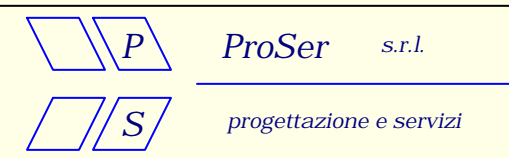

TITOLO		UGBS - Schema a Blocchi	
FORMATO	CODICE	REV	
A4			
PROTEL Adv. Sch. Cap Foglio di			

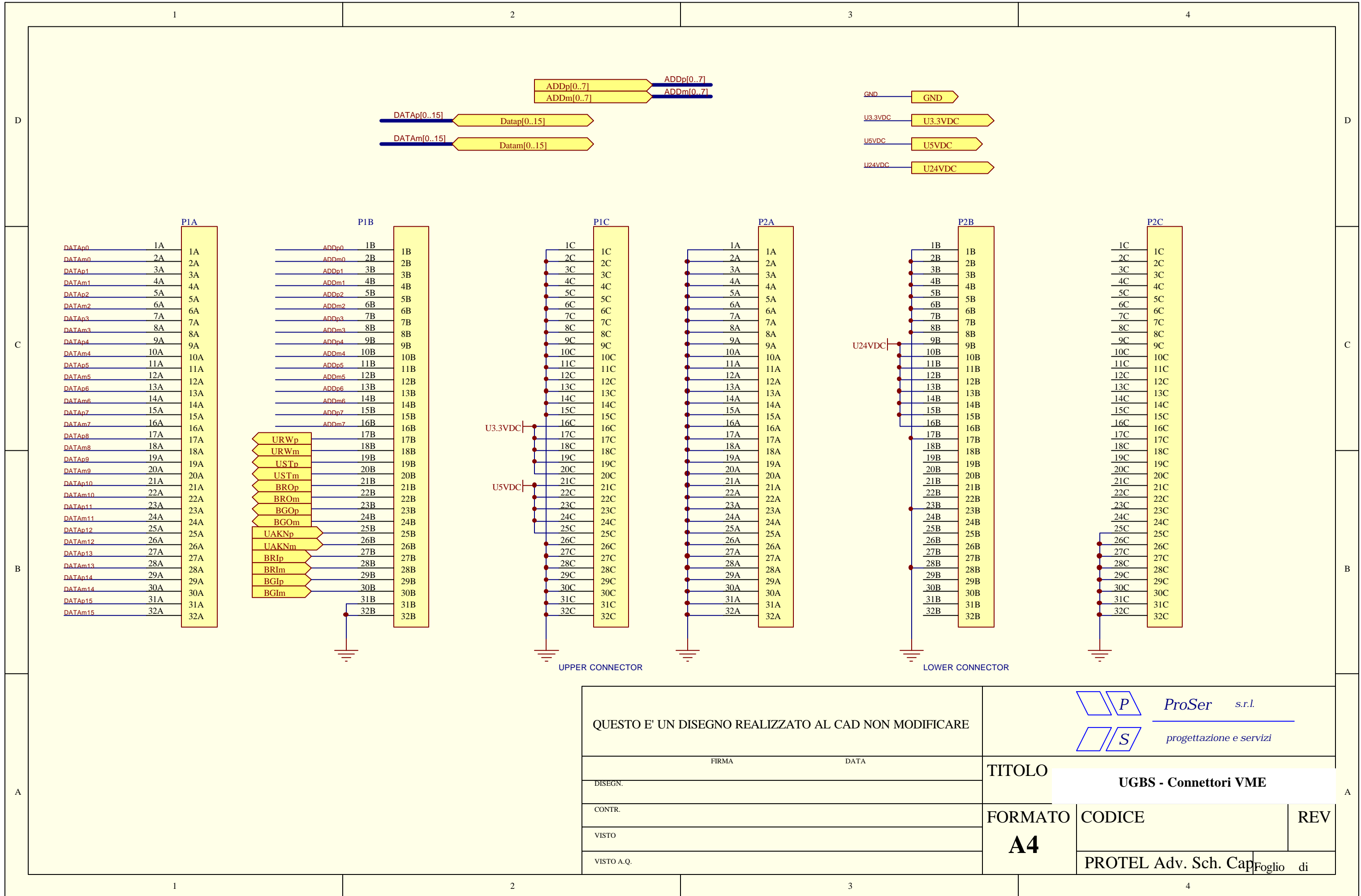

QUESTO E' UN DISEGNO REALIZZATO AL CAD NON MODIFICARE

FIRMA _____ DATA _____

DISEGN. _____

CONTR. _____

VISTO _____

VISTO A.Q. _____



TITOLO **UGBS - Connettori VME**

FORMATO **A4** CODICE _____ REV _____

PROTEL Adv. Sch. Cap _____ Foglio di _____

D

D

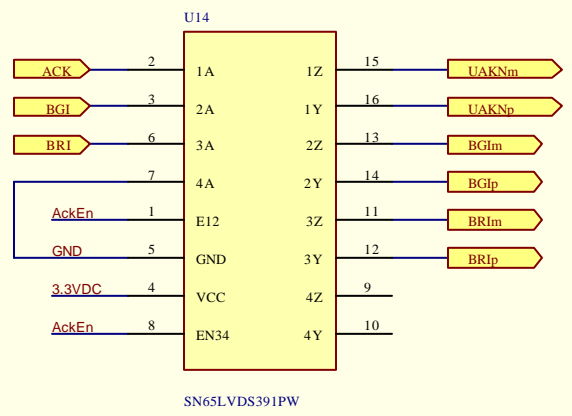
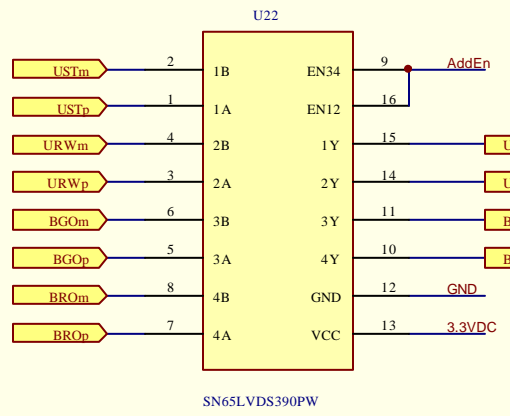
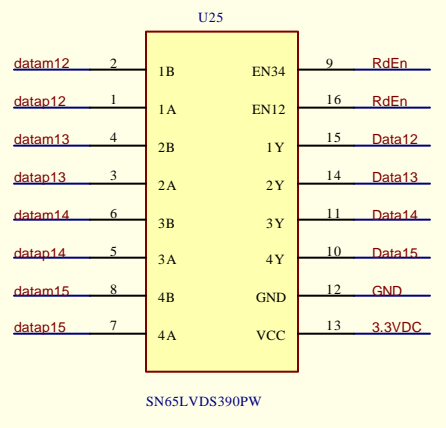
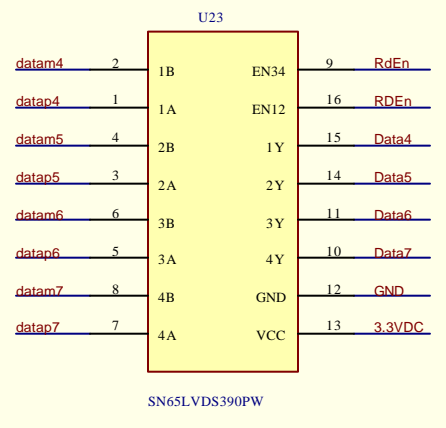
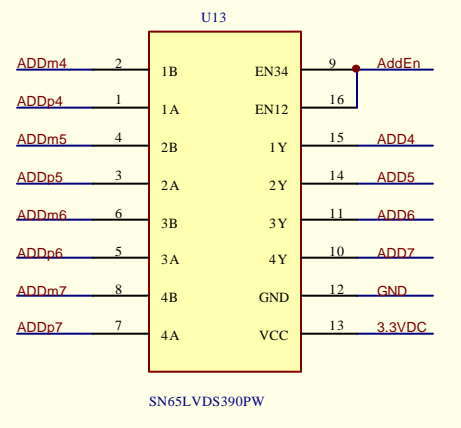
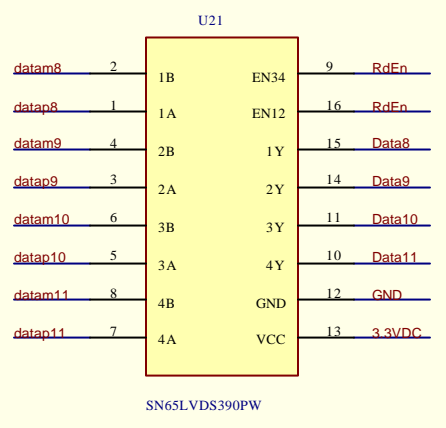
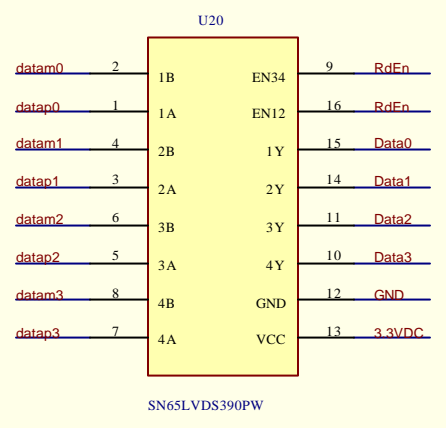
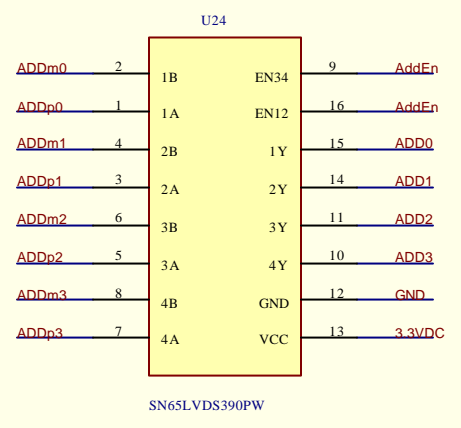
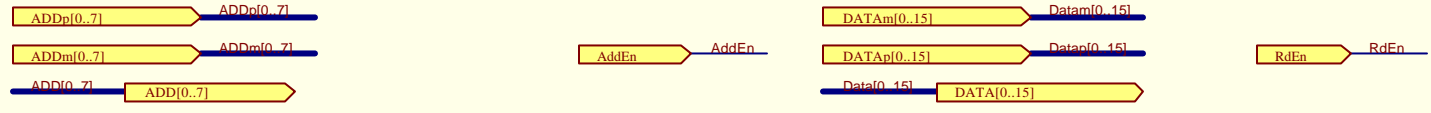

C

C

B

B

A

A

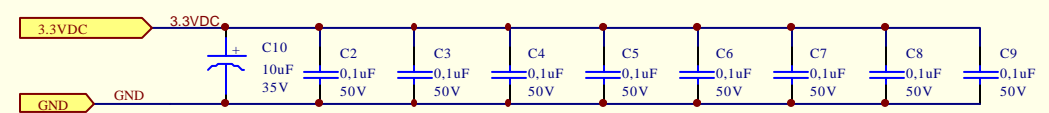

QUESTO E' UN DISEGNO REALIZZATO AL CAD NON		ProSer s.r.l. progettazione e servizi
PRODOTTO	DATA	
TITOLO	UGBS - IO-IN	
FORMATO	CODICE	REV
A3	PROTEL Adv. Sch. Cd	Foglio di

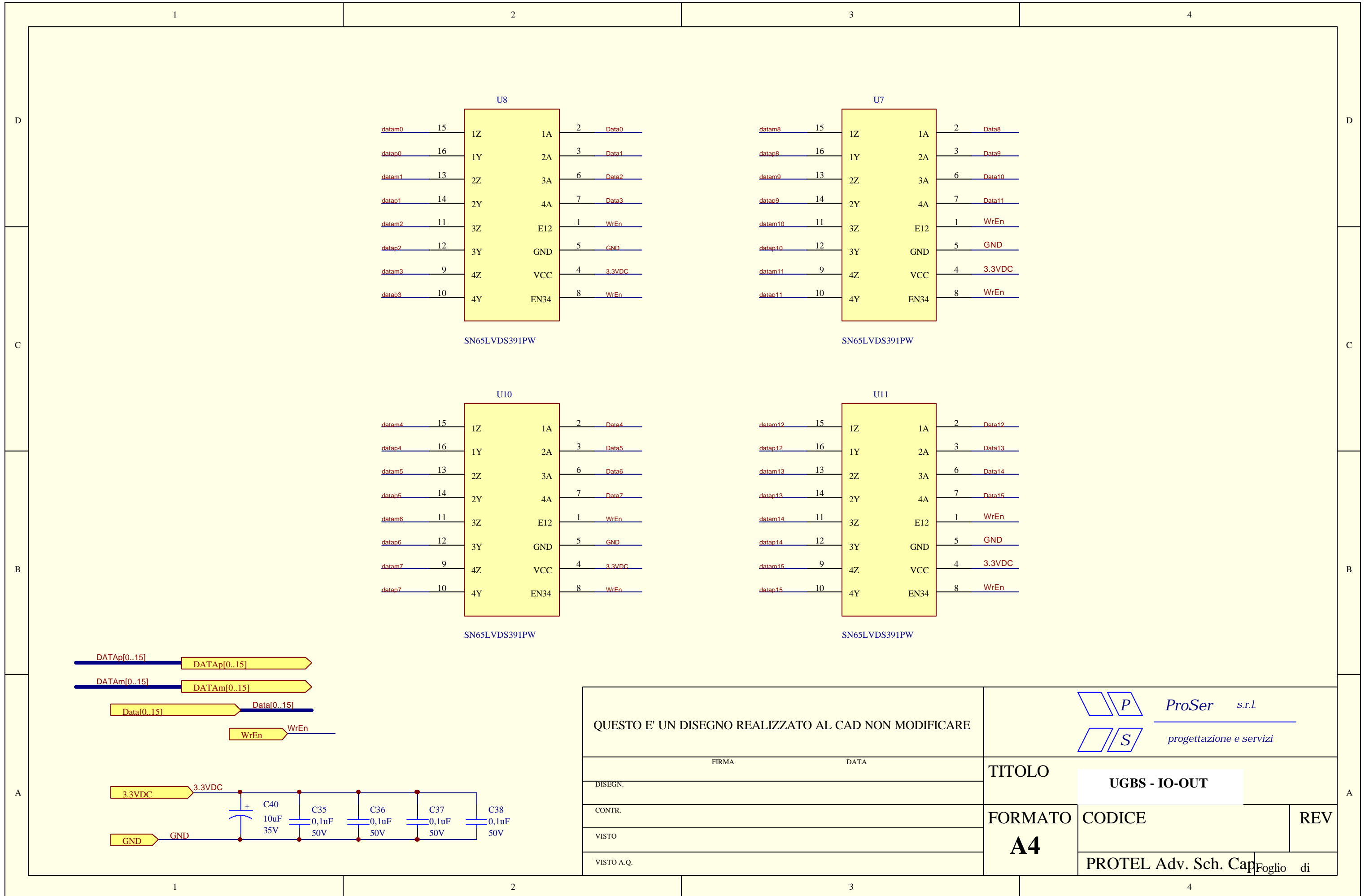

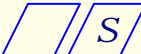
QUESTO E' UN DISEGNO REALIZZATO AL CAD NON MODIFICARE		 ProSer s.r.l.  progettazione e servizi	
FIRMA	DATA	TITOLO	
DISEGN.		UGBS - IO-OUT	
CONTR.		FORMATO	REV
VISTO		A4	
VISTO A.Q.		PROTEL Adv. Sch. Cap Foglio di	

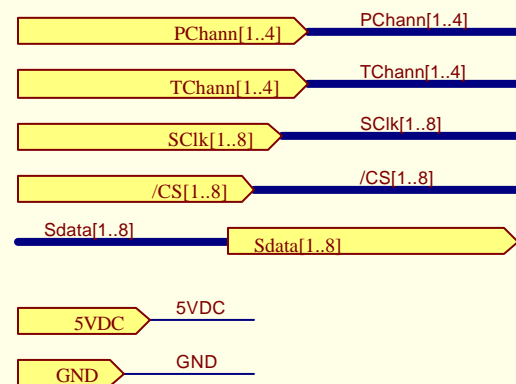
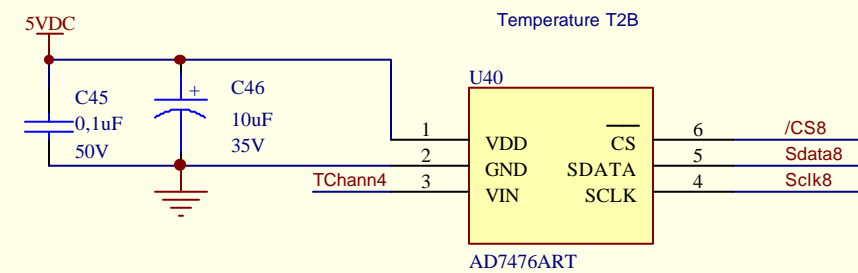
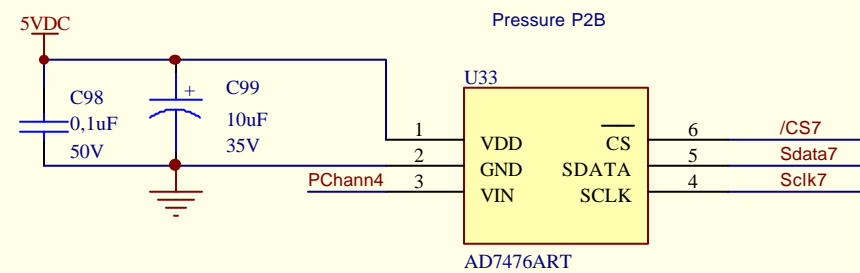
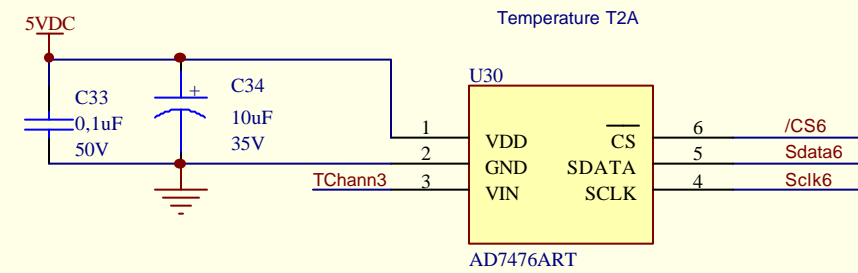
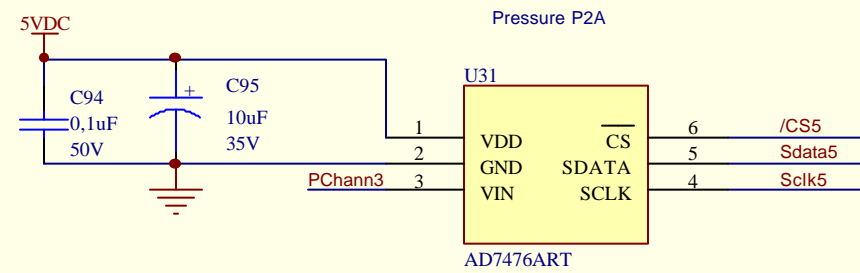
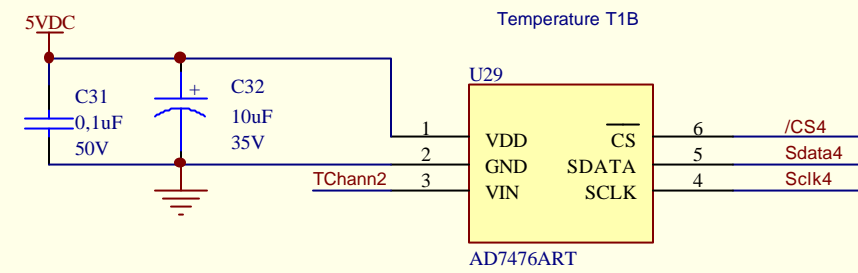
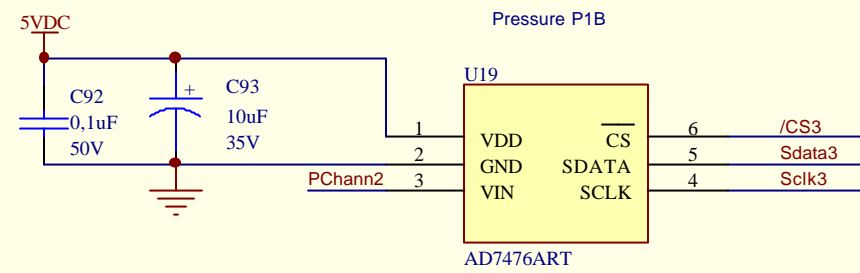
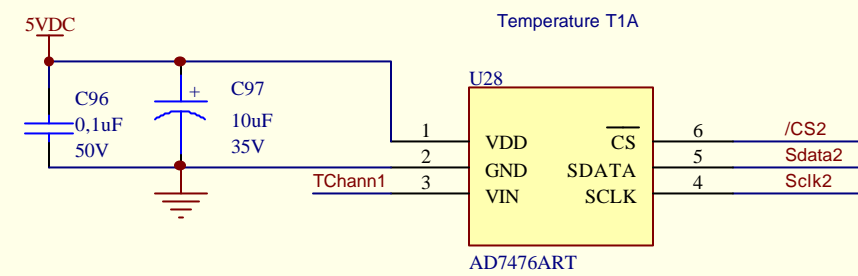
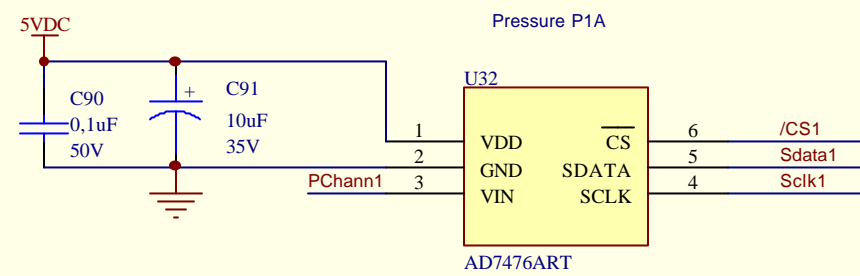

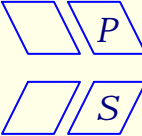
QUESTO E' UN DISEGNO REALIZZATO AL CAD NON MODIFICARE		 ProSer s.r.l. progettazione e servizi	
FIRMA	DATA	TITOLO	
DISEGN.		UGBS - AD-8	
CONTR.		FORMATO	CODICE
VISTO		A4	REV
VISTO A.Q.		PROTEL Adv. Sch. Cap Foglio di	

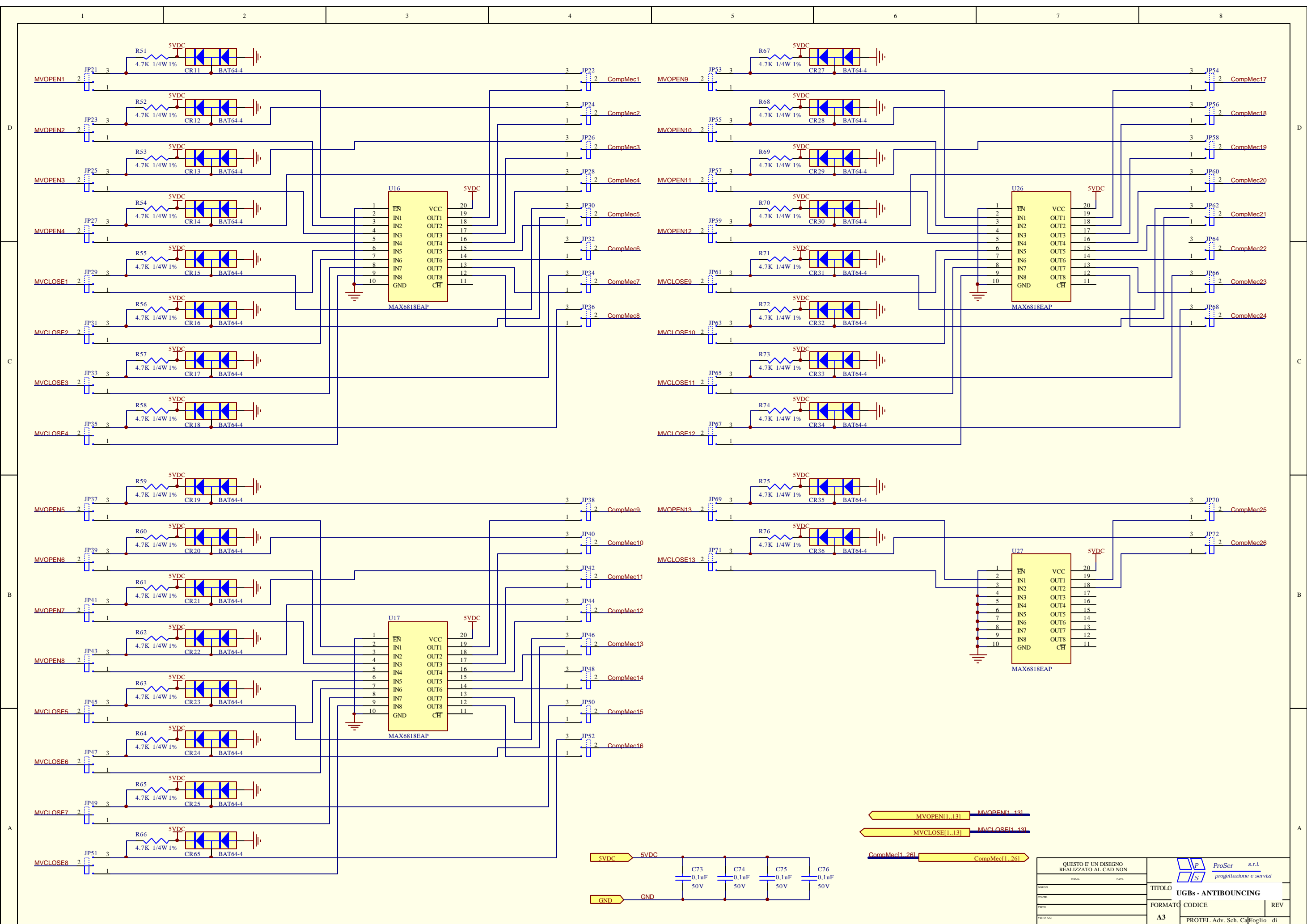

QUESTO E' UN DISEGNO REALIZZATO AL CAD NON		 ProSer s.r.l. progettazione e servizi
PRODOTTO	DATA	
TITOLO		UGBs - ANTIBOUNCING
FORMATO	CODICE	REV
A3	PROTEL Adv. Sch. Cd	Foglio di

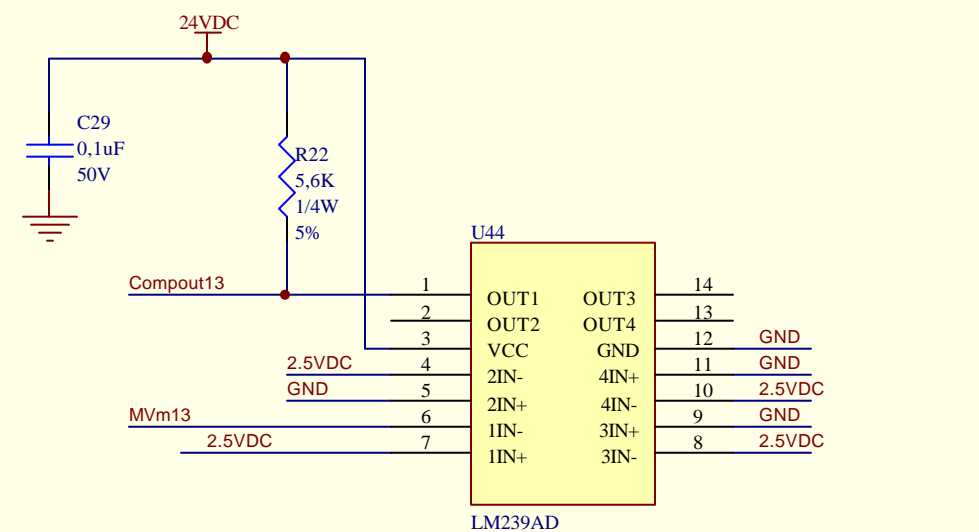
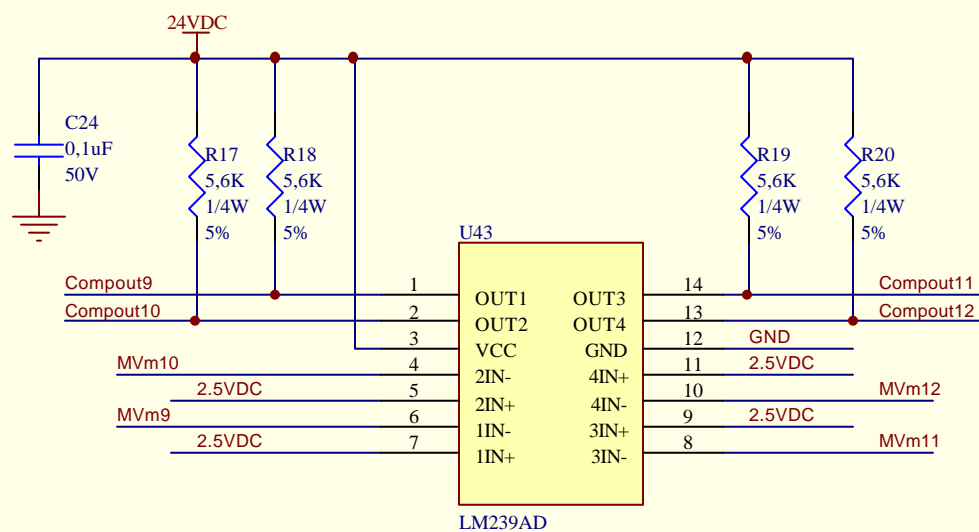
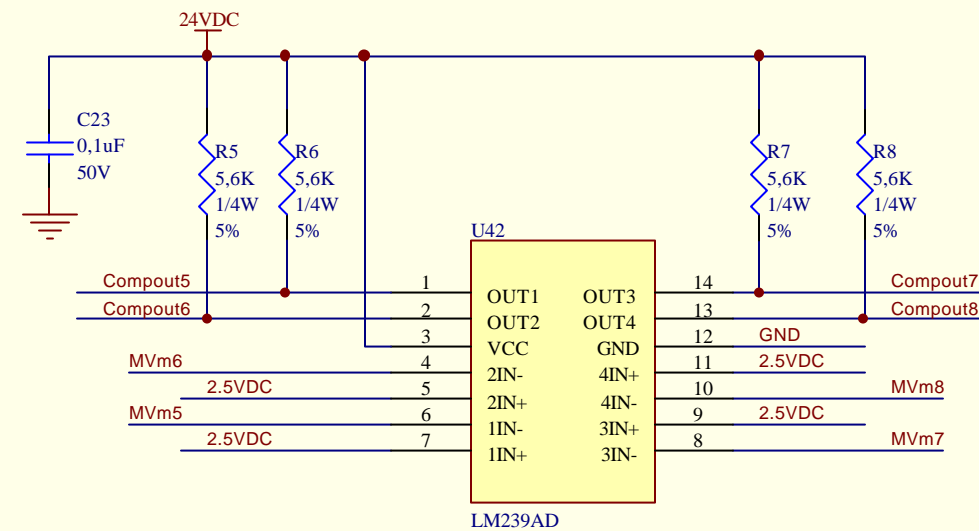
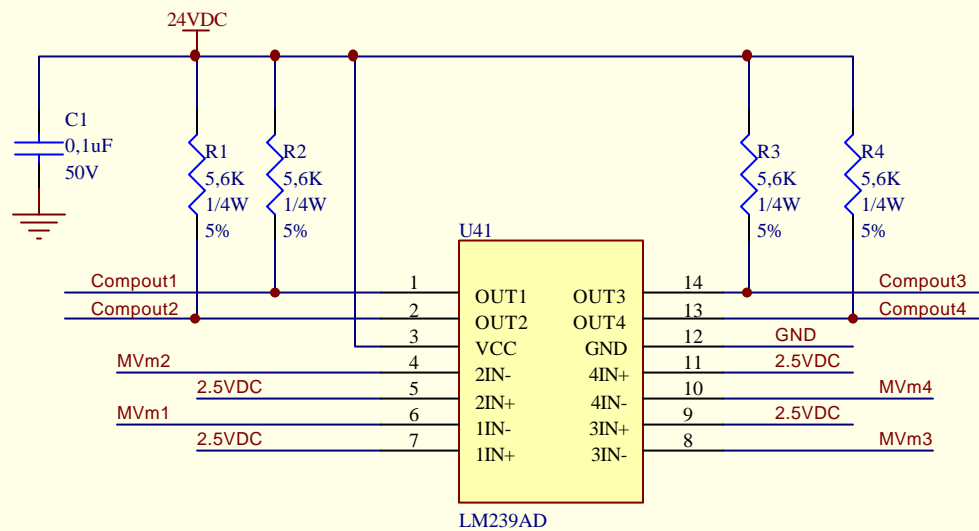

COMPOUT[1..13] COMPOUT[1..13]

2.5VDC 2.5VDC

MVm[1..13] MVm[1..13]

24VDC 24VDC

GND GND

QUESTO E' UN DISEGNO REALIZZATO AL CAD NON MODIFICARE

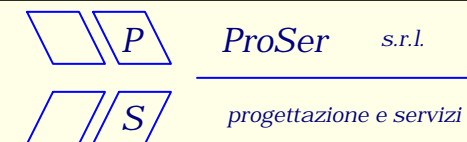

FIRMA DATA

TITOLO

DISEGN.

CONTR.

VISTO

VISTO A.Q.

FORMATO

CODICE

REV

A4

PROTEL Adv. Sch. CapFoglio di

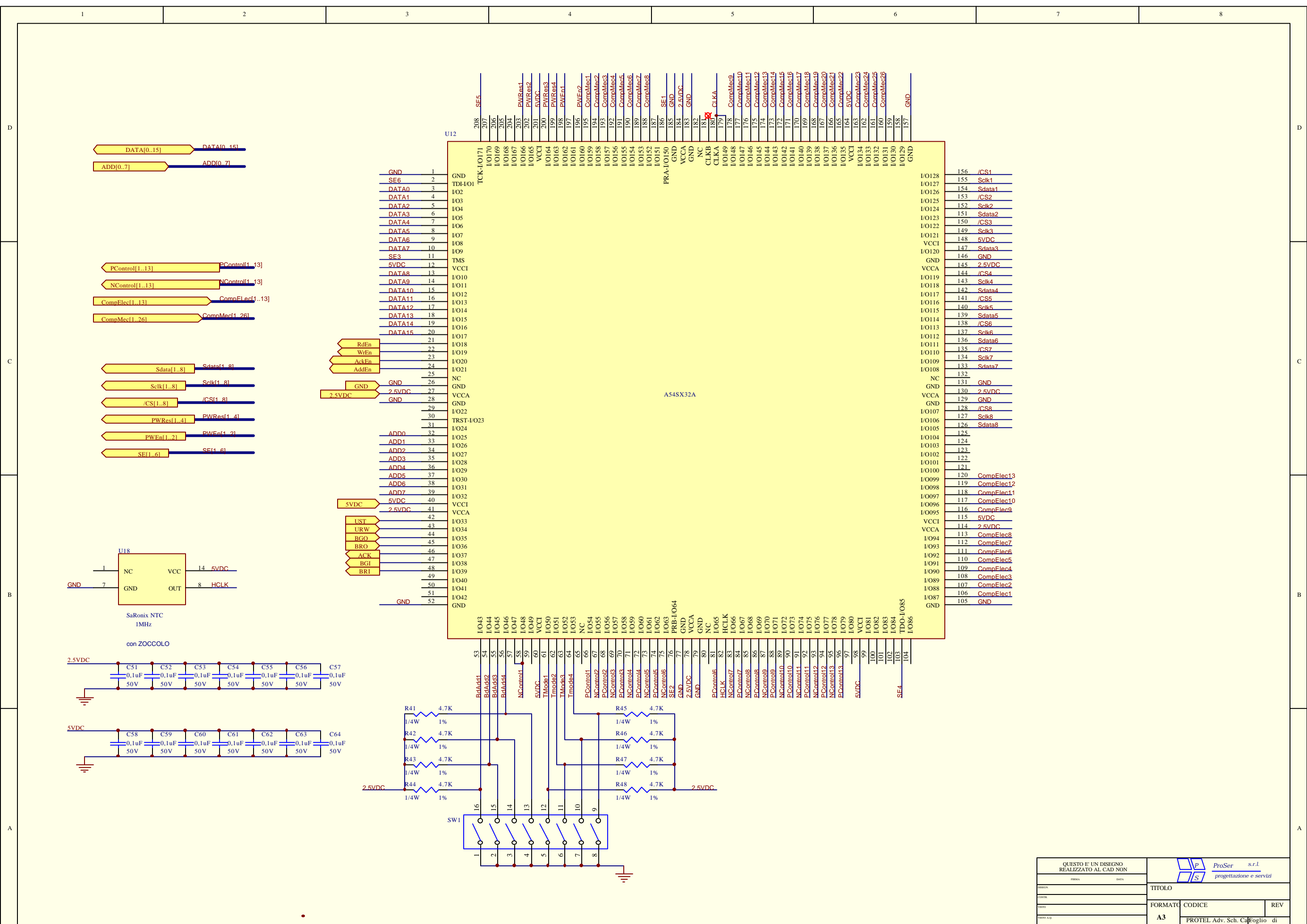

QUESTO E' UN DISEGNO REALIZZATO AL CAD NON		ProSer s.r.l. progettazione e servizi
PRODOTTO	DATA	
TITOLO		FORMATE
CODICE		REV
A3		PROTEL Adv. Sch. Cd Foglio di

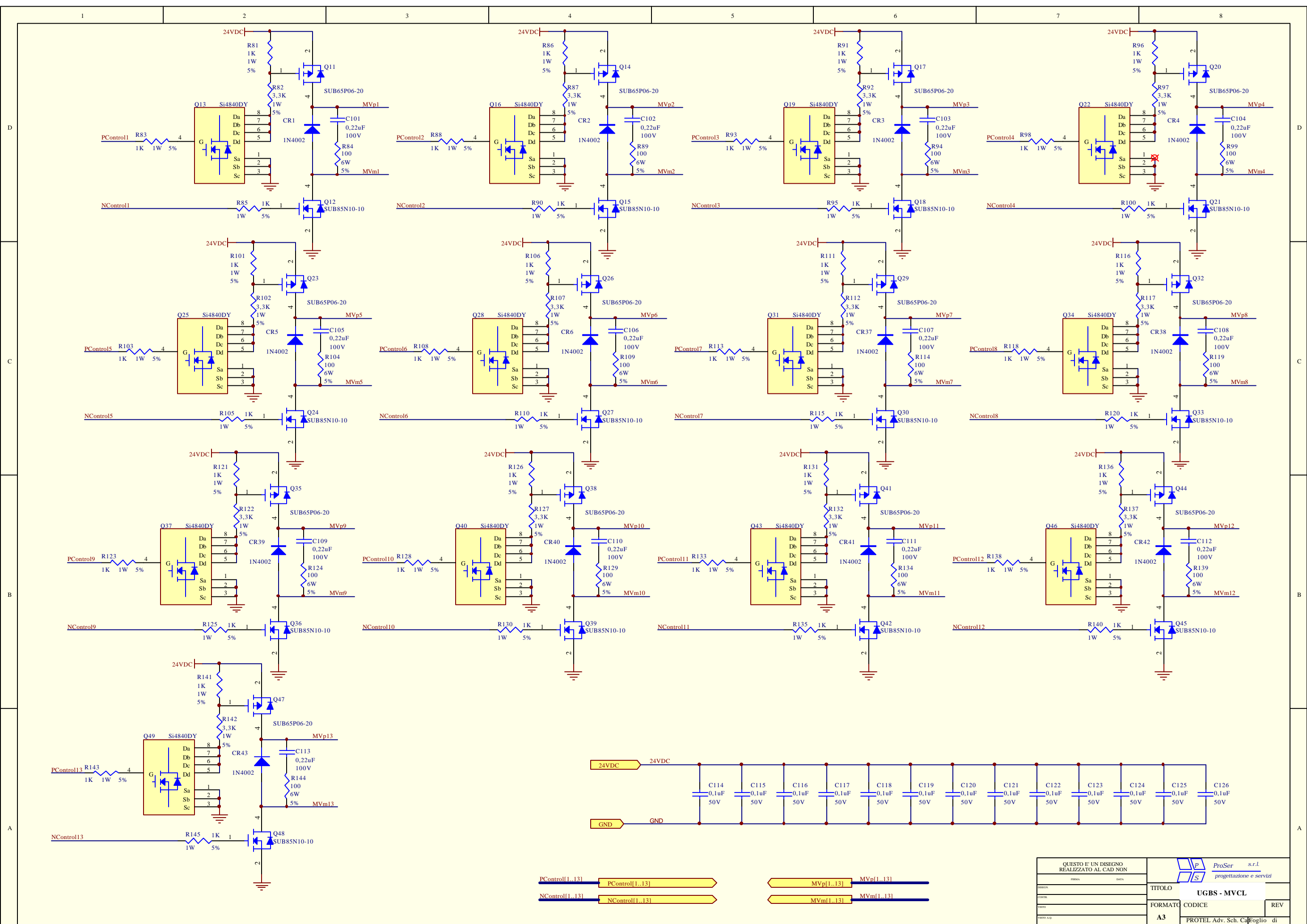

QUESTO E' UN DISEGNO REALIZZATO AL CAD NON		 ProSer s.r.l. progettazione e servizi
PRODOTTO	DATA	
TITOLO		UGBS - MVCL
FORMATO	CODICE	
A3		REV
PROTEL Adv. Sch. CdE foglio di		

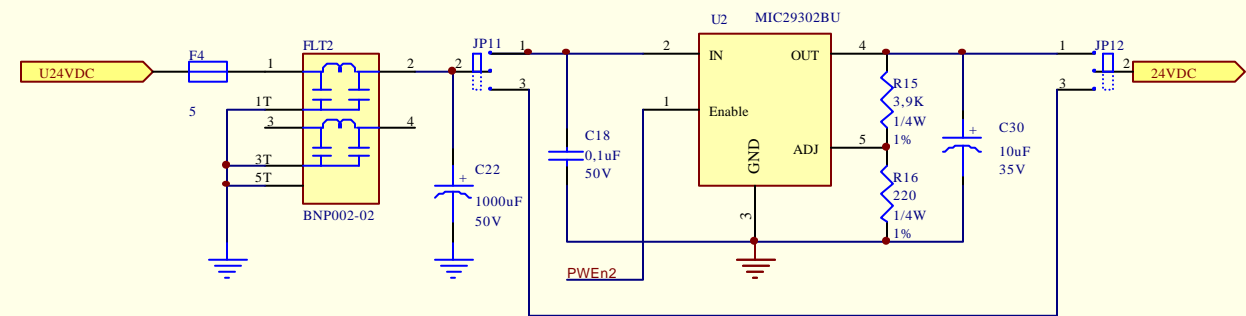
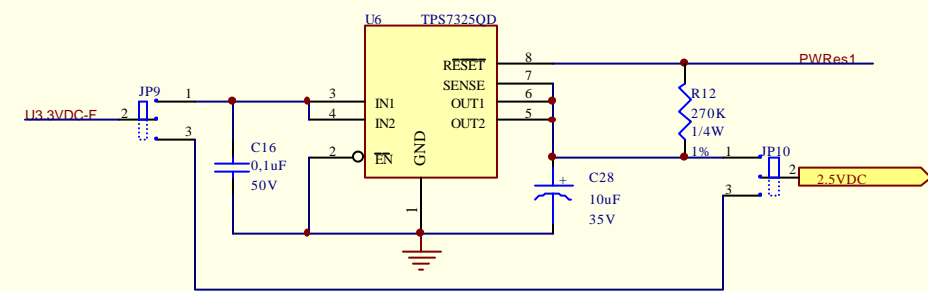
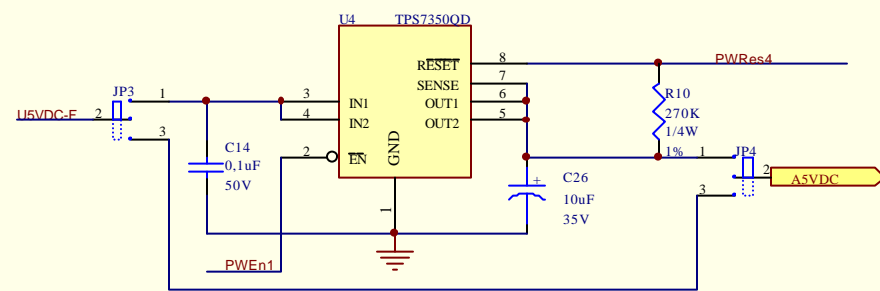
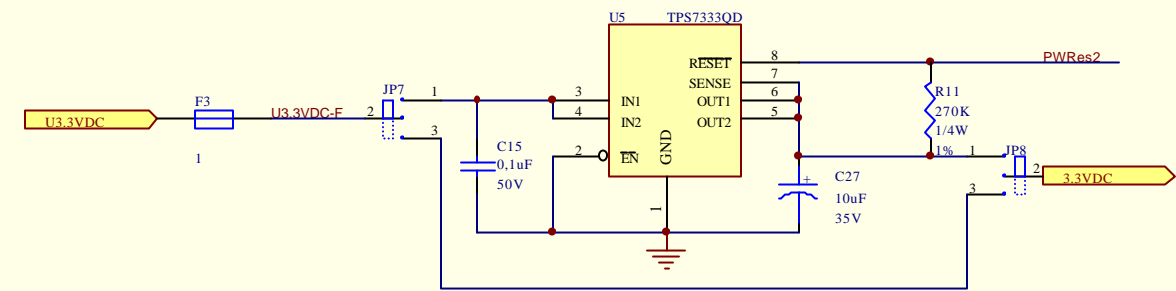
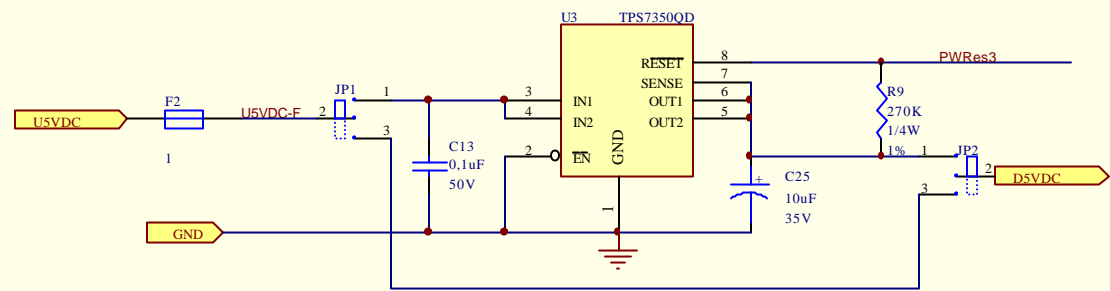

PWRes[1..4] → PWRes[1..4]

PWEs[1..2] → PWEs[1..2]

QUESTO E' UN DISEGNO REALIZZATO AL CAD NON			
PRODOTTORE	DATA	TITOLO	UGBS - Power
CONTO		FORMATO	CODICE
VEDI		A3	REV
PRODOTTORE		PROTEL Adv. Sch. CdE foglio di	

1

2

3

4

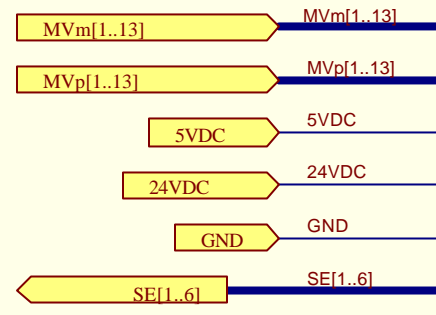

ACTEL Silicon Explorer Interface

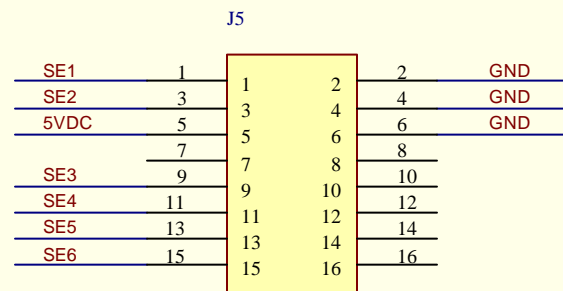

IDC-16

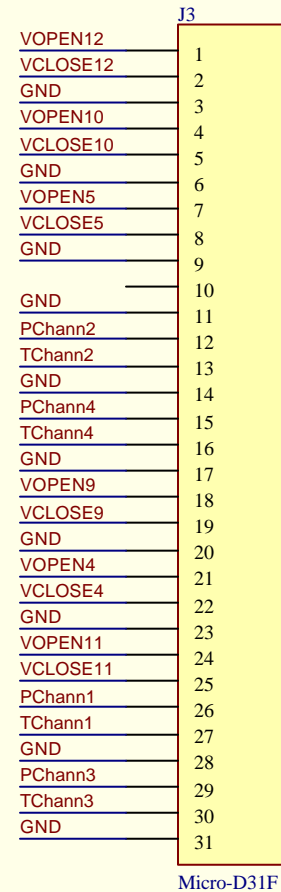

Micro-D31F

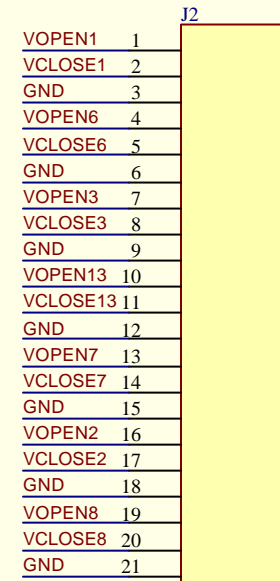

Micro-D21F

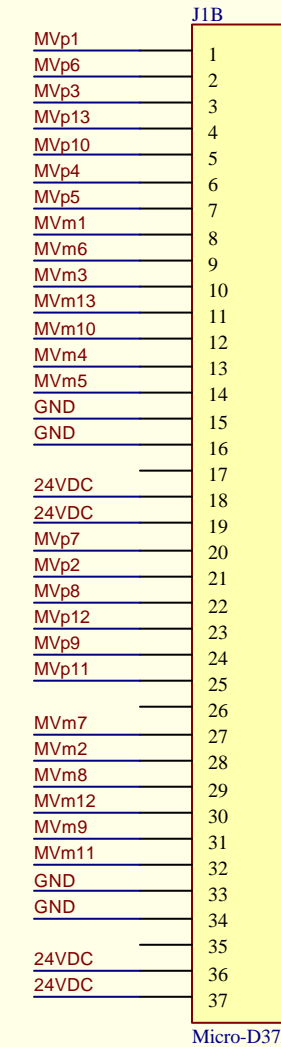

Micro-D37F

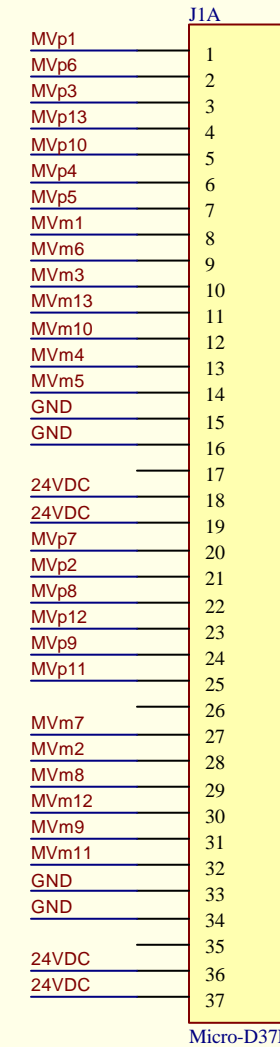

Micro-D37F

QUESTO E' UN DISEGNO REALIZZATO AL CAD NON MODIFICARE



FIRMA	DATA
DISEGN.	
CONTR.	
VISTO	
VISTO A.Q.	

TITOLO		
UGBS - Conn-Out		
FORMATO	CODICE	REV
A4		
PROTEL Adv. Sch. Cap		Foglio di

1

2

3

4