



# A programmable front-end system for arrays of bolometers

A. Alessandrello<sup>a</sup>, C. Brofferio<sup>a</sup>, C. Bucci<sup>b</sup>, O. Cremonesi<sup>a</sup>, A. Giuliani<sup>a</sup>,  
A. Nucciotti<sup>a</sup>, M. Pavan<sup>a</sup>, M. Perego<sup>a</sup>, G. Pessina<sup>a,\*</sup>, S. Pirro<sup>a</sup>,  
E. Previtali<sup>a</sup>, M. Vanzini<sup>a</sup>

<sup>a</sup>INFN Istituto Nazionale di Fisica Nucleare, e Dipartimento di Fisica dell'Università di Milano-Bicocca, Via Celoria 16, 20133 Milano, Italy

<sup>b</sup>Laboratori Nazionali del Gran Sasso, Strada Statale 17bis Km 18 + 910, 6700 Assergi (L'Aquila), Italy

---

## Abstract

We report on a new front-end system developed to readout an array of large mass bolometers. The front-end allows setting all the necessary parameters for each detector by remote control. A special circuit, also fired remotely, has been developed in order to adjust the output voltage, allowing the DC coupling to the detector. © 2000 Elsevier Science B.V. All rights reserved.

---

## 1. Introduction

In view of the implementation of the experiment CUORE, an array consisting of 1000 large mass TeO<sub>2</sub> bolometric detectors, we are running underground, in the Gran Sasso Laboratory, 20 of such bolometers each having a mass of about 340 g. With this system we have already started a measurement of the double beta decay of <sup>130</sup>Te [1]. The subject of this contribution is the description of the front-end readout implemented for the 20 crystals prototype detector. The approach adopted is based on a programmable system, able to compensate for the residual spread of the dynamic and static characteristics observed within the detector array. In the following, each part constituting the front-end, except for the input preamplifier which is

described elsewhere [2], will be addressed. In particular, the remote interface with the computer will also be described.

## 2. The front-end readout and its remote control

Dynamic and static characteristics of identical bolometers vary over a range that depends mainly on the detector-heat sink thermal link reproducibility [3], and on the uniformity of thermistor's parameters. The prototype array of 20 large-mass TeO<sub>2</sub> crystal detectors we have implemented, shows a dispersion among the various properties of each element that is contained within a factor of two [1].

To compensate for the above residual non-uniformity it is then necessary to adjust some parameters for each channel, a very uncomfortable procedure if made all manually. A system programmable remotely is therefore preferred.

Figs. 1(a) and (b) show the schematic diagram of our solution. The parts that are indicated with the

---

\*Corresponding author. Tel.: +39-02-23-92-329; fax: +39-02-706-09-512.

E-mail address: pessina@mi.infn.it (G. Pessina).

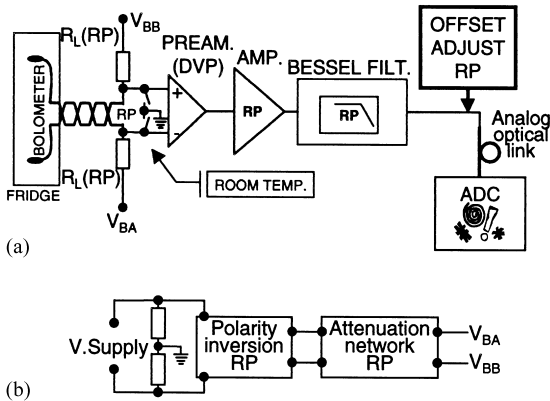

Fig. 1. The block diagram of the whole front-end. The parts that are remotely programmable are indicated with the symbol RP. (a) Shows the complete analog link, (b) the detector bias network details.

symbol RP are programmable remotely. The present version of the readout has at the input a Differential Voltage Sensitive Preamplifier (DVP), Fig. 1(a), which operates at room temperature [2]. The resistors  $R_L$  (Surface Mounted, by Siegert Electronic), which load the bolometer, are also located at room temperature. To minimize the thermal noise contribution, their value can be selected (by shorting/not-shortng them), with four positions, 2 G $\Omega$ , 22 G $\Omega$ , 96 G $\Omega$ , 116 G $\Omega$ , the choice depending on the bolometer resistance. The connection from the room-temperature front-end to the low-temperature bolometer is made by means of a pair of twisted wires. With the differential configuration adopted, common mode disturbances such as microphonism and cross talk between adjacent channels are attenuated.

The DVP inputs can be connected to ground. The polarity of the bias voltage can be inverted independently for each detector channel and an attenuating resistive network is present, having 3 bits of resolution, Fig. 1(b). Only one precise and stable supply voltage, V.Supply, an HP6627A, is then needed for the whole detector system. This input network arrangement allows making a full DC characterization of the bolometer, taking into account the preamplifier input current contribution [4].

The overall gain of the front-end can be set, with 4 bits of resolution, acting on the resistances value

which form the loop gain of the second stage amplifier, AMP. The analog bandwidth can be changed in four steps, from 12 Hz up to a few tens of kHz by selecting the time constant of the Bessel filter. A low-noise linear optical buffer amplifier [5] connects each analog output to the ADC.

The supply voltage for the array has been developed appositely, having a high Power Supply Rejection Ratio (PSRR), low noise and very low drift [6].

Finally, a special circuit has been developed able to adjust the output offset voltage at a preset value, with 15 bits of resolution. With the maximum selectable voltage gain of 10,000, it is possible to set the final voltage with an error of about 30 mV, for the limiting case in which the bolometer is biased with 0.1 V.

Each detector channel has its own address, consequently it can be programmed individually. A 10 bits bi-directional bus is connected to each channel of the array, the other end being controlled by an I/O digital board, located inside a computer. A digital optical link is put in between to avoid ground loops. The communication is made on a multi-instruction basis. Two of the 10 bits bus give the indication of the meaning of the other 8 bits: board address, instruction word or data (setting) to be stored on the board, and state reading command. Each communication with a board needs at least four steps: channel addressing, instruction to be executed, data to be stored and logoff from the channel. Multi-instruction and data storing are also possible.

The program that controls the whole system has been developed with LabWindow CVI. Many features are available, such as storing and restoring of the whole array setup, verification of the correct connection and operation of each channel, and offset adjustment of the whole array. Moreover, all the above features can be applied to each channel individually.

### 3. Hardware implementation

A special care has been taken for the implementation of the logic circuitry that controls the readout. The logic network, implemented with

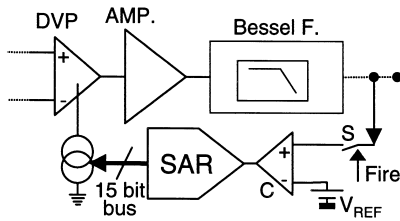

Fig. 2. Schematic diagram for the offset adjustment. The procedure is started by the command Fire, which closes the switch S for the time necessary.

standard digital circuits, has been designed to be shut down when not used. No clock and timers are active during signal acquisition, for avoiding the possible presence of spikes and interference. The translation from the voltage level of the digital commands, coming from the logic circuit, to the analog level commands, able to drive the switches having suitable ON–OFF characteristics, has been developed on purpose.

The input network, detector bias voltage, load resistors and DVP inputs connections, are switched ON or OFF by means of relays of bistable type, Matsushita Nais TX2-L2-12V. These relays have two coils, one for each of the two possible positions. Once in one position, the relay maintains, stores, the setting until fired in the other state. This is useful for two reasons: it allows to leave the coils unbiased during normal operation, minimizing electromagnetic interference, and it minimizes power dissipation due to the saving of current absorption in the coils. In the input network the use of relay switch is necessary for obtaining very large shunt resistances when in an open state.

Where very large impedances are not necessary for the open state condition (AMP. gain or Bessel bandwidth), MOS transistors with very low ON resistance ( $5 \Omega$ ) were used instead.

The offset adjustment circuit has been based on the Successive Approximation technique [7]. The schematic diagram is shown in Fig. 2. When the output offset must be regulated, a remote command closes the switch S. A successive approximation register, SAR, composed with the cascade of two 8-bits Motorola MC14559B, sets high one of its output bits, starting from the MSB. An analog

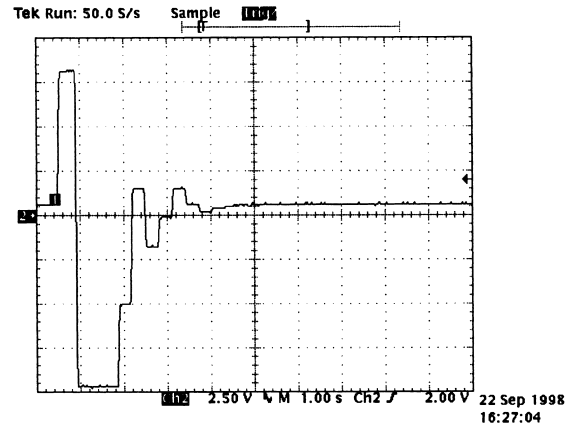

Fig. 3. Tek photograph of the offset adjusted to a target value of 0.5 V. Horizontal scale is 1 s/div, vertical scale is 2.5 V/div.

current having the corresponding weight is added inside the DVP. The resulted front-end output is compared with the target voltage  $V_{REF}$  by the comparator C. The logic inside the SAR samples the comparator output, and sets the actual state of the bit under test. This procedure is repeated for all the 15 bits of the SAR. Contrary to what is made in the standard Analog to Digital conversion, the SAR sampling period, in our solution is given by a clock which have a period larger than the settling time of the whole front-end. This has given excellent results: in this way the arrangement behaves like an open-loop network and it is not necessary to include a dominant pole, dependent on the gain and bandwidth selected, to make stable the feedback loop. Irrespective of the selected gain, the only constraint needed is to set the clock period slower than the smaller bandwidth selectable, 12 Hz in our case.

After a preset time the switch S is opened and the SAR maintains the needed reference current: the front-end output remains close to the target voltage. The experimental result of Fig. 3 shows that in a few seconds it is possible to adjust the offset with very good accuracy.

Another feature has been implemented in the offset correction procedure that is not shown in Fig. 2. If the correction is fired while a particle having a large energy has developed a signal, a

wrong final value may result. To avoid this, the circuit forces the switch S to stay closed for a few seconds after the correction procedure has terminated. If, during this period, the output does not remain confined in a preset voltage window centered around  $V_{\text{REF}}$ , the offset correction procedure is fired again.

#### 4. Conclusions

A new system readout for an array of bolometers has been developed. It allows the setting of all the necessary parameters by means of remote controls. Since the system is DC coupled to each channel, a special circuit, also fired remotely, has been developed to adjust the output offset irrespective of the selected gain and bandwidth, without the necessity to include a dominant pole. This front-end system is at present used to readout an array of 20 TeO<sub>2</sub> bolometric detectors operated in the Gran Sasso Underground Laboratory.

#### References

- [1] A. Alessandrello, C. Brofferio, D.V. Camin, O. Cremonesi, E. Fiorini, A. Giuliani, A. Nucciotti, M. Pavan, G. Pessina, S. Pirro, E. Previtali, L. Zanotti, C. Bucci, *Phys. Lett. B* 433 (1998) 156.
- [2] G. Pessina, *Nucl. Instr. and Meth. A* 444 (2000) 132. These Proceedings.
- [3] R.C. Jones, *J. Opt. Soc. of Amer.* 43 (1953) 1.
- [4] A. Alessandrello, C. Brofferio, D.V. Camin, O. Cremonesi, A. Giuliani, A. Nucciotti, M. Pavan, M. Perego, G. Pessina, S. Pirro, E. Previtali, M. Sisti, *Cryogenics* 37 (1997) 27.
- [5] D.V. Camin, G. Pessina, *IEEE Trans. Nucl. Sci.* (1998), submitted for publication; and *Nucl. Instr. and Meth. A* 444 (2000) 140. These Proceedings.
- [6] G. Pessina, A low noise, low drift, high precision linear bipolar ( $\pm 10$  V) voltage supply/reference for cryogenic front-end apparatus, *Rev. Sci. Instr.*, to be published.
- [7] See for instance: R.L. Geiger, P.E. Allen, N.R. Strader, *VLSI, Design Technique for Analog and Digital Circuits*, McGraw-Hill, New York, 1990, p. 651.