

Preliminary results on the search for neutrinoless double beta decay of ^{130}Te with the **Cuoricino** experiment

Angelo Nucciotti

Dip. di Fisica "G. Occhialini",

Università di Milano-Bicocca, Milano, Italia

on behalf of the CUORE collaboration



*Dipartimento di Fisica dell' Università and Sez. INFN di Milano- Milano - Italy
Lawrence Berkeley Laboratory, Berkeley - California- USA*

*Dip. di Scienze Chimiche, Fisiche e Matematiche dell'Università dell' Insubria e
Sez. INFN di Milano - Como - Italy*

*Dipartimento di Fisica dell'Università and Sez. INFN di Firenze- Firenze- Italy
Kamerling Onnes Laboratory, Leiden University- Leiden -The Netherlands
Laboratori Nazionali del Gran Sasso, INFN - L'Aquila - Italy*

*Department of Physics and Astronomy, University South Carolina - Columbia S. C. - USA
Laboratori Nazionali di Legnaro, INFN - Padova - Italy
Lab. of Nucl. and High En. Physics, University of Zaragoza - Zaragoza - Spain*

International Europhysics Conference on High Energy Physics,



Introduction to $\beta\beta - 0$

$\beta\beta - 2$: $(A, Z) \rightarrow (A, Z+2) + 2e^- + 2\bar{\nu}_e$

- allowed in Standard Model
- $t_{1/2} > 10^{19}$ years

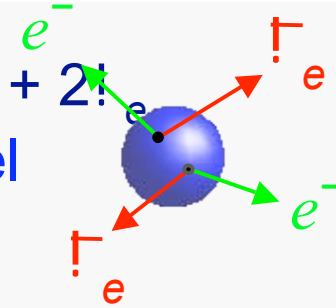

$\beta\beta - 0$: $(A, Z) \rightarrow (A, Z+2) + 2e^-$

- not allowed in Standard Model (! $L=2$)

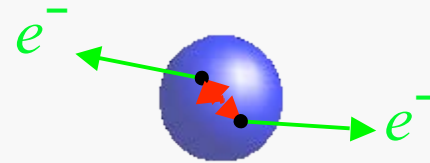

$$\beta\beta - 0 \Leftrightarrow m_1 \neq 0$$

- expected mechanism:

nuclear physics

$$\langle m \nu \rangle = \sum_k m_k \nu_k \left| \sum_l U_{kl} \right|^2$$

→ in some mass schemes $0.01 < m_1 < 1.0$ eV

neutrino mixing matrix

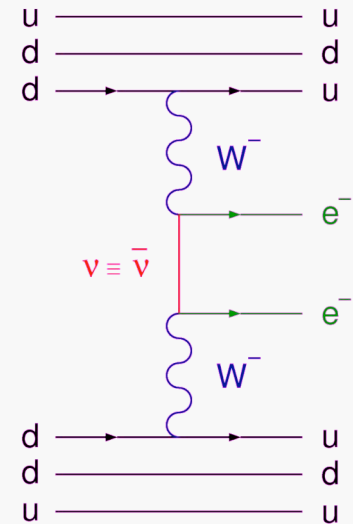

Thermal detectors

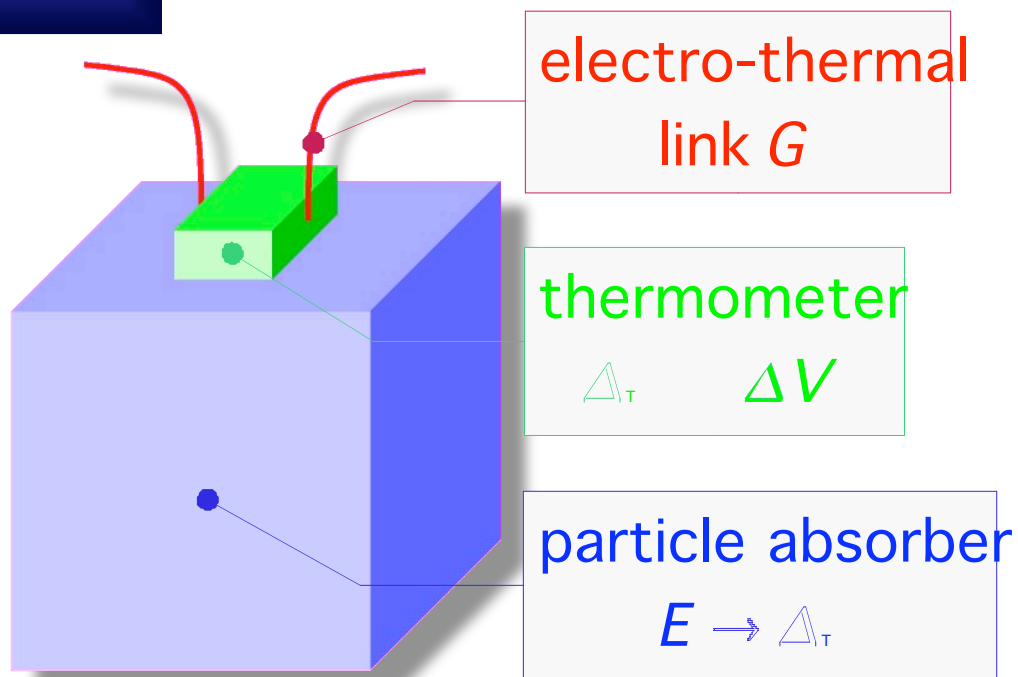

Thermal Detectors Properties

- ▲ high energy resolution
- ▲ large choice of absorber materials
- ▲ true calorimeters
- ▼ slow $\tau = C/G \sim 1 \div 10^3$ ms

Detection Principle

- $T = E/C$
 C thermal capacity
 \Rightarrow low C
 \Rightarrow low T (i.e. $T \ll 1\text{K}$)
 \Rightarrow dielectrics, superconduct
- ultimate limit to sensitivity:
statistical fluctuation of internal energy U
 $" \Delta U^2 " = k_B T^2 C$

- example: 760 g of TeO_2 @ 10 mK
 $C \sim T^3$ (Debye) $\Rightarrow C \sim 2 \times 10^{-9}$ J/K
1 MeV γ -ray $\Rightarrow \Delta T \sim 80$ μK
 $\Rightarrow \Delta U \sim 10$ eV

!! -0! search with TeO₂ calorimeters



Calorimeters

- source \subseteq detector
 - ▲ large N_{nuclei}
 - ▲ high energy resolution !
 - ▲ high efficiency
- measure $E = E_{!1} + E_{!2}$
- signature: a peak at $Q_{!1}$

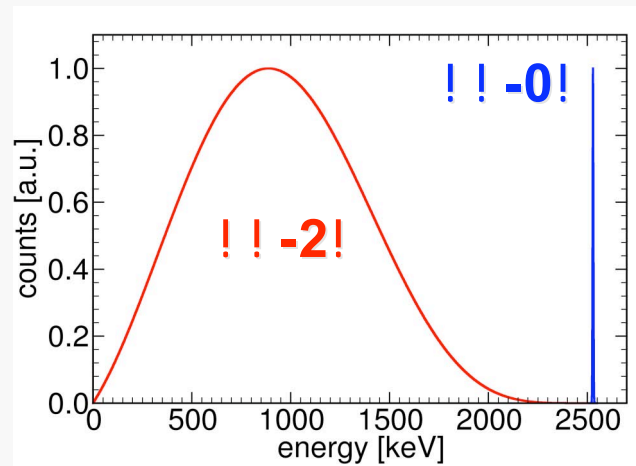

TeO₂ thermal calorimeters

- Active isotope ^{130}Te
 - ▲ natural abundance: a.i. = 33.9%
 - ▲ transition energy: $Q_{!1} = 2529 \text{ keV}$
 - ▲ “short” predicted half life
- " $m_1 \approx 0.3 \text{ eV} \Leftrightarrow t_{1/2}^{0!} \approx 10^{25} \text{ years}$ "
- Absorber material TeO₂
 - ▲ low heat capacity
 - ▲ large crystals available
 - ▲ radiopure

! 1/2 0! sensitivity

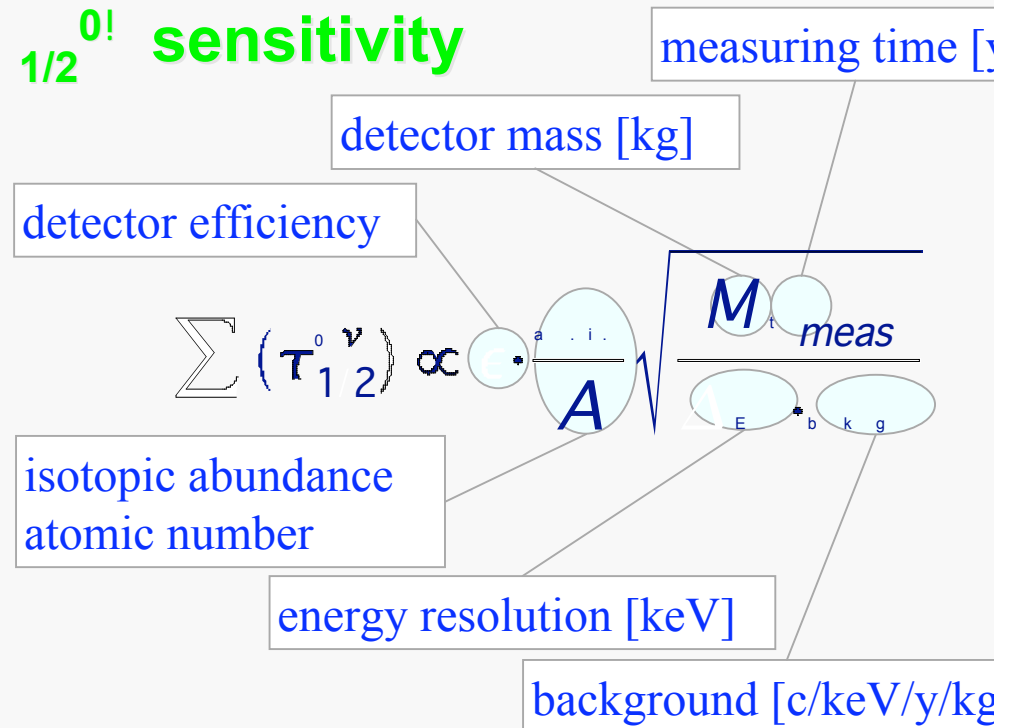



Final Mibeta experiment results

1997-2001

Laboratori Nazionali del Gran Sasso, Hall A

! array of 20 TeO_2 detectors 340 g each

▶ total mass 6.8 kg of TeO_2

! total statistics 4.3 kg×y

▶ $b \approx 0.3$ counts/keV/years/kg @ $Q_{\beta\beta}$

▶ $t_{1/2} \geq 2.1 \times 10^{23}$ years at 90% C.L.

▶ " $m_{\beta\beta}$ " $\geq 1.1 \div 2.6$ eV at 90% C.L. (*)



C. Arnaboldi, et al., Phys. Lett. B557 (2003) 167

(*) spread in " $m_{\beta\beta}$ " due to uncertainty in nuclear matrix element F_N



The CUORE experiment

Cryogenic Underground Observatory for Rare Events

- array of 1000 TeO_2 crystals $5 \times 5 \times 5 \text{ cm}^3$ (790 g)
⇒ 790 kg granular calorimeter
- !! -0! , Cold Dark Matter, Axions searches

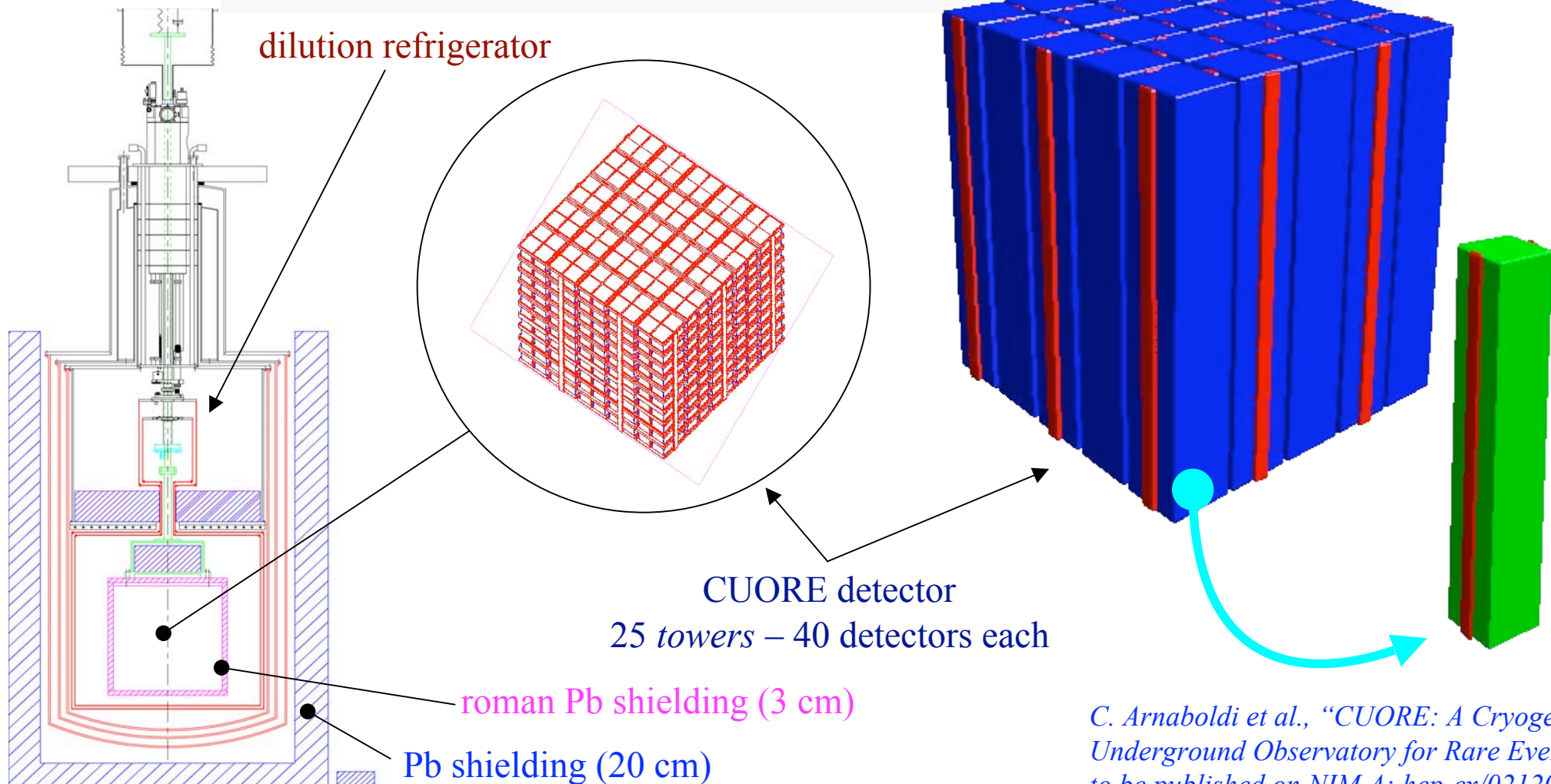

C. Arnaboldi et al., "CUORE: A Cryogen Underground Observatory for Rare Event to be published on NIM A: hep-ex/021205



CUORE !! -0! expected sensitivity

! **CUORE !! -0!** sensitivity will depend strongly on the background level

! for $b = 1$ count/ton/year/keV

and ! $E = 5$ keV

in 5 years

▶ ! $t_{1/2}^{0!} ! 6.8 \times 10^{26}$ years at 1!

▶ " m_1 " ! 19 ÷ 46 meV

▲ spread in " m_1 " comes from nucleon matrix element F_N uncertainty

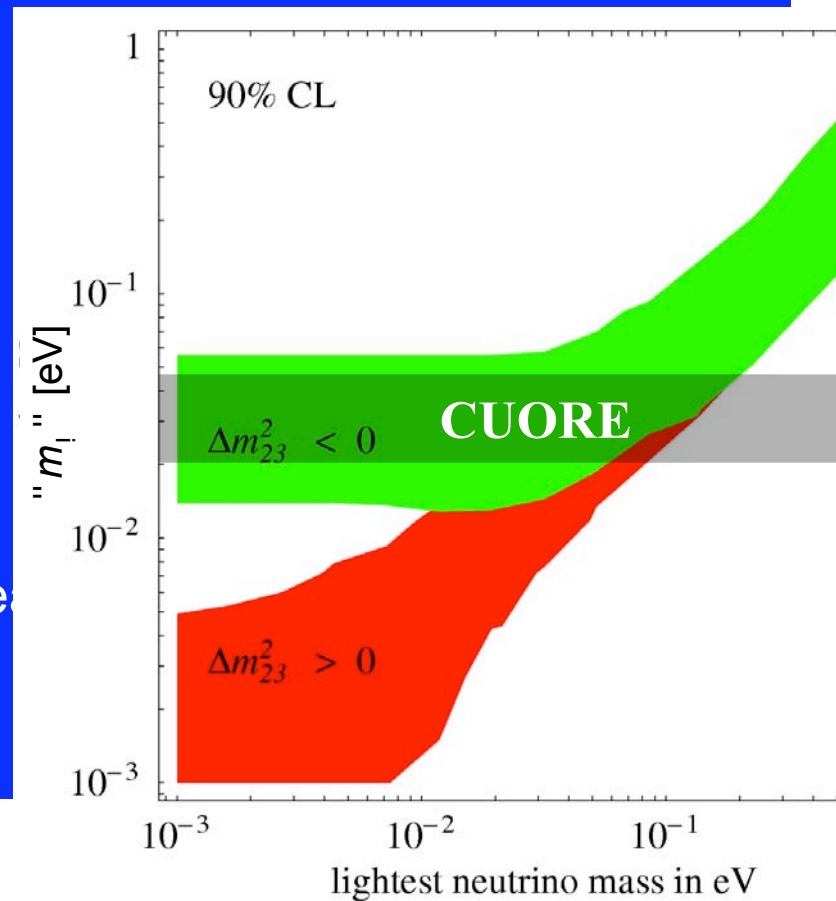

C. Arnaboldi et al., "Physics Potential and Prospects for the Cuoricino and CUORE experiments", to be published on Astroparticle Physics

F.Feruglio et al., Nucl. Phys. B637 (2002) 345; hep-ph/0201291

The Cuoricino experiment



1 CUORE *tower* ! Cuoricino experiment

- test for large mass TeO_2 detectors
- test for the *tower-like* structure of **CUORE** sub-elements
- test for surface cleaning techniques

! *independent* experiment: it will give important results on

▶ ^{130}Te Neutrinoless Double Beta Decay

▶ WIMP Dark Matter

Laboratori Nazionali del Gran Sasso, Hall A



Cuoricino set-up

Cuoricino tower: 62 TeO₂ crystals

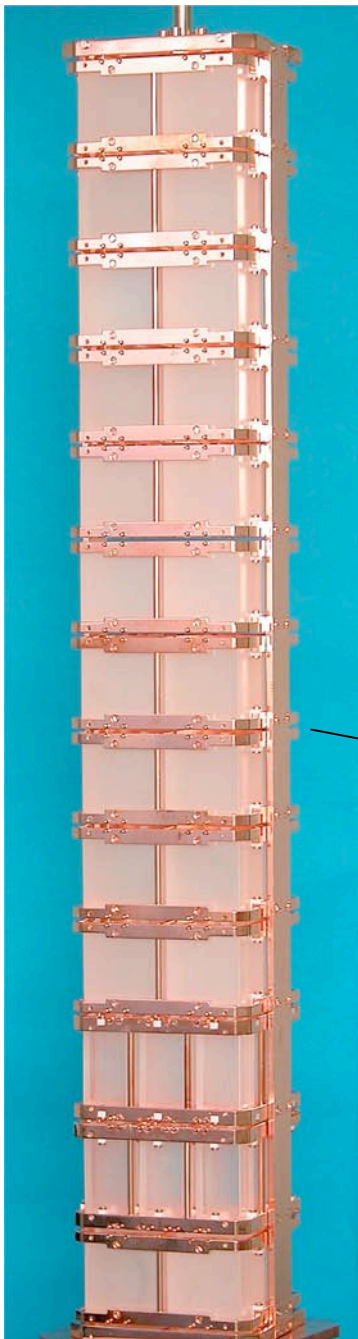

2.7 m

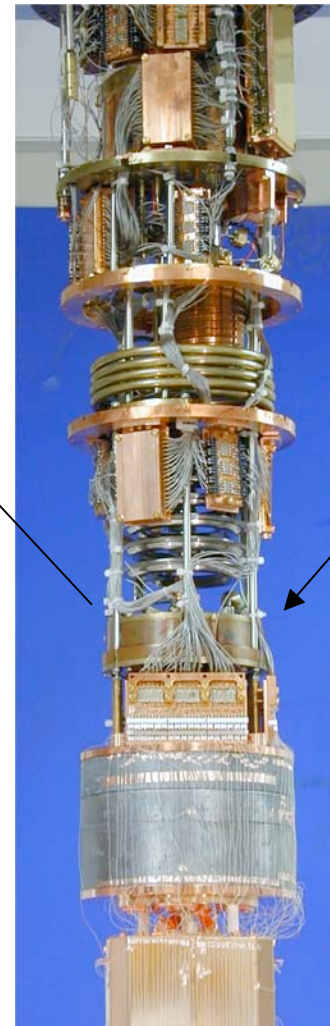
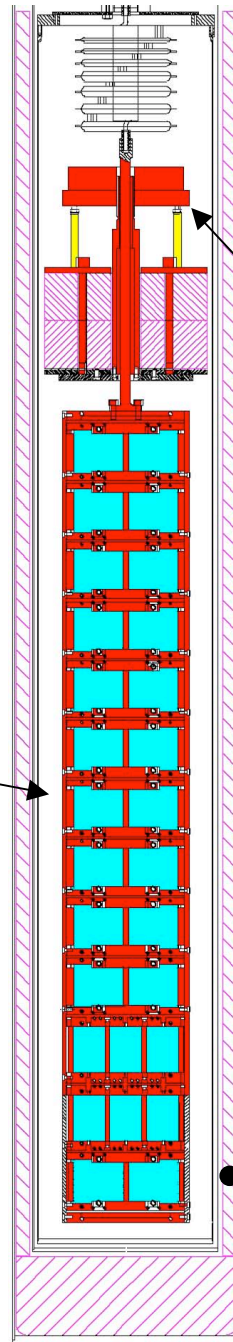

mixing char
 $T \approx 6$ ml

roman Pb shielding (1 cm lateral)
external shields:
! 10 cm Pb + 10 cm low act Pb
! neutron shield: B-polyethylene
! nitrogen flushed anti-radon box

Cuoricino mounting



- ! careful cleaning of Cu and TeO_2 surfaces
- ! detector assembling done in cleanest conditions
 - ▶ clean room
 - ▶ nitrogen atmosphere to avoid radon contamination





Cuoricino detectors

- 11 modules with 4 detectors
 - ↳ 44 TeO_2 crystals
 - ↳ $5 \times 5 \times 5 \text{ cm}^3 \Rightarrow 790 \text{ g}$
 - ▷ TeO_2 mass $\Rightarrow 34.76$

- 2 modules with 9 detectors
 - ↳ 18 TeO_2 crystals
 - ↳ $3 \times 3 \times 6 \text{ cm}^3 \Rightarrow 330 \text{ g}$
 - ▷ TeO_2 mass $\Rightarrow 5.94 \text{ kg}$
- 4 crystals are enriched
 - ↳ $2 \times {}^{130}\text{TeO}_2 + 2 \times {}^{128}\text{TeO}_2$

- total active mass
 - ▷ TeO_2 ! 40.7 kg
 - ▷ ${}^{130}\text{Te}$! 14.1 kg
 - ▷ ${}^{128}\text{Te}$! 0.54 kg

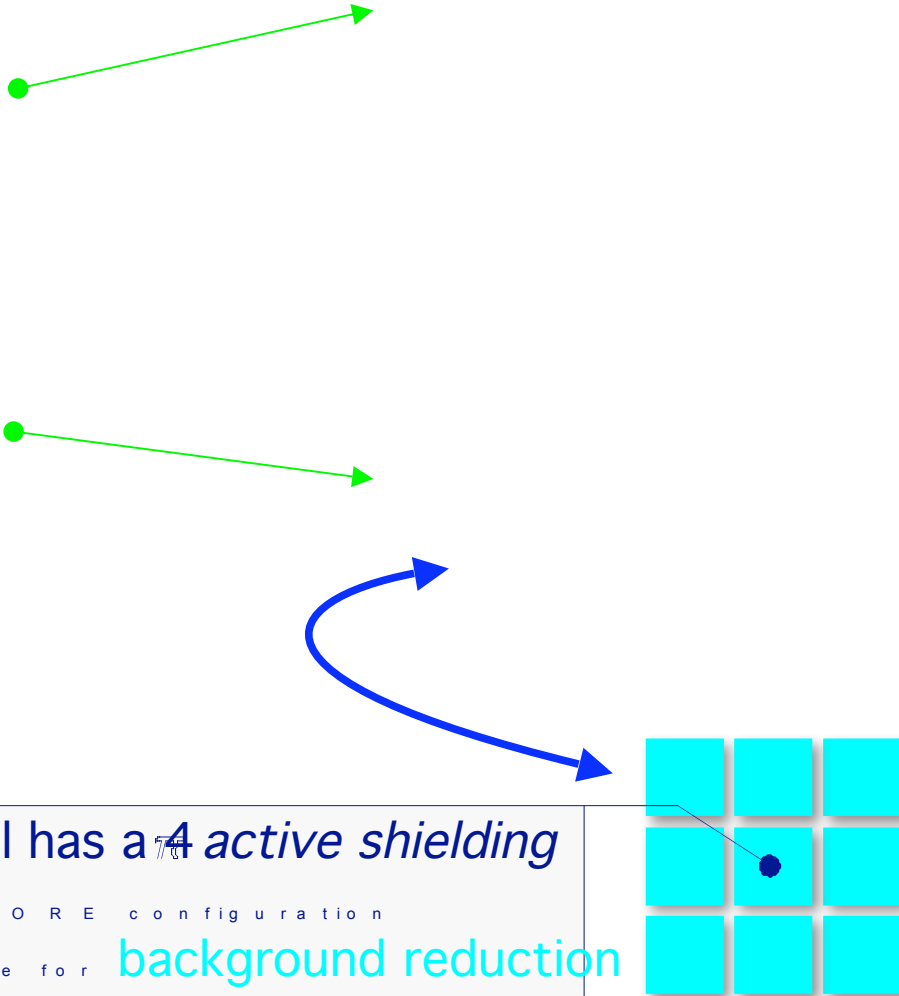

central crystal has a 4 active shielding

like in CUORE configuration

⇒ anti-coincidence for background reduction



Cuoricino detectors in present run

□ due to the failure of some wires during cooldown
few detectors are disconnected

- ▷ 330 g crystals: 16 working
 - ▶ 3.96 kg of TeO_2
- ▷ 790 g crystals: 32 working
 - ▶ 25.28 kg of TeO_2

total working mass

- ▷ ^{130}Te : 10.4 kg
- ▷ ^{128}Te : 0.54 kg

790 g ! " E_{FWHM} " ≈ 7 keV

330 g ! " E_{FWHM} " ≈ 9 keV

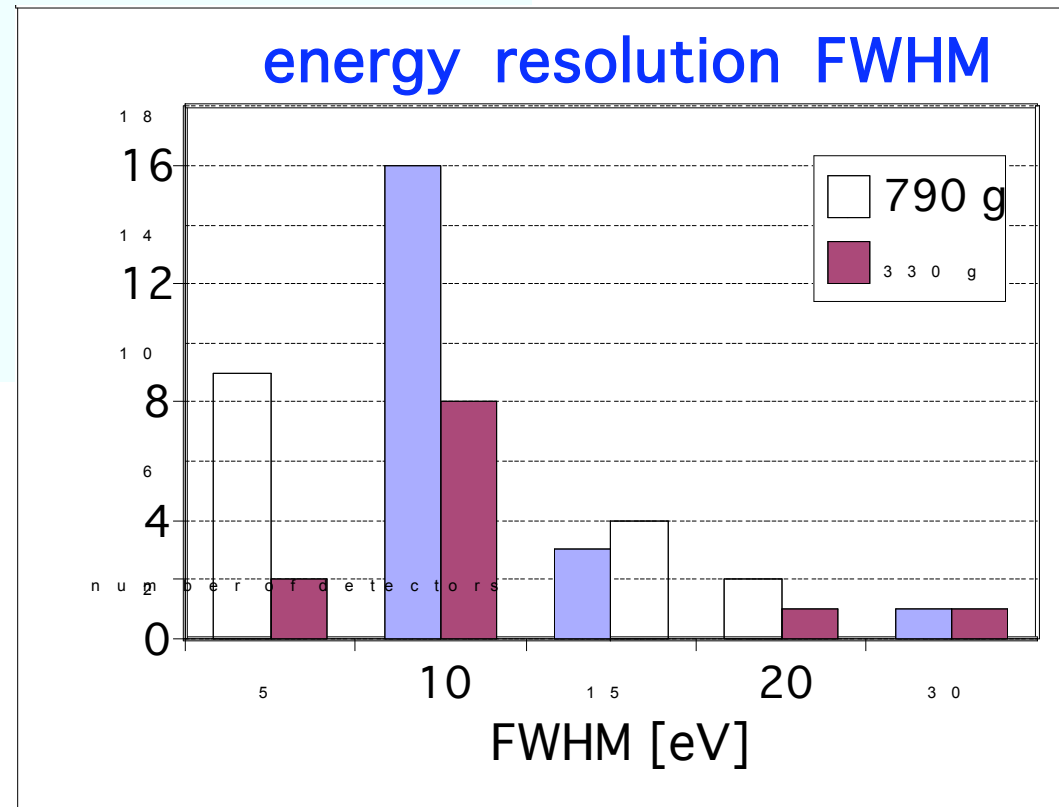

analysis of 330 g detectors is not yet available



Cuoricino present status

start: april 19th, 2003

stop: june 23rd, 2003 (due to temporary LNGS shutdown)

²³²Th calibration
(only 790 g crystals)

background measurement
(only 790 g crystals in anticoincidence)

- 227.73 h
 - ▷ "!" E = 8 keV @ 2615 keV

- 891.27 h (\approx 1.2 months)
 - ▷ 57% live time
 - ▷ $b = 0.23 \pm 0.04$ c/keV/y/kg @



Most recent results from Cuoricino

anticoincidence sum spectrum

(only 790 g crystals)

2.26 kg×y

$t_{1/2} \geq 5 \times 10^{23}$ years at 90% C.L.

" m_1 " $\leq 0.7 \div 1.7$ eV

counts

preliminary result on ^{130}Te

energy [keV]

decays



Cuoricino and CUORE outlook

- ! *tower*-like arrays of large mass TeO_2 detectors are feasible
- ! surface cleaning techniques are under control
- ! CUORE *R&D* will concentrate on further background reduction

! Cuoricino is a scientifically interesting experiment

▶ " m_1 " ! **$0.7 \div 1.7$ eV at 90% C.L.** (2.3 kg×y, ≈ 1 month live-time)

! Cuoricino started running again on July 7th, 2003

▷ with $b = 0.23$ counts/keV/years/kg, ! $E = 8$ keV

and the full 40.7 kg TeO_2 mass working (new wires are in preparation)

▶ ! $t_{1/2}$! **4×10^{24} years at 90% C.L. in ≈ 3 years (≈ 120 kg×y)**

▶ " m_1 " ! **$0.25 \div 0.60$ eV**

m 0.7-1.7

dE 8keV

2480-2600

0.23⁺⁷⁻ 0.04 c/keV/kg/y anti (Solo 5x5x5)

3 anni

1e25

m 0.16-0.38



Outline

- ! introduction to $0\nu\beta\beta$
- ! thermal detectors applied to the $0\nu\beta\beta$ search
- ! the CUORE project
- ! the Cuoricino experiment
 - ▶ detectors
 - ▶ experimental set-up
 - ▶ performances
 - ▶ background
 - ▶ new limit on $0\nu\beta\beta$
- ! Status of CUORE project
- ! conclusions

- 1.copertina
- 2.outline
- 3.introduzione bb
- 4.intro rivelatori
- 5.calorimetri bb
- 6.CUORE e Cuoricino
- 7.scopo e sensibilita' CUORE
- 8.Cuoricino set-up
- 9.Cuoricino foto
- 10.Cuoricino stato (calibrazione)
- 11.Fondo alfa
- 12.fondo gamma
- 13.limite
- 14.futuro