

NEWS FROM CERN

PLENARY ECFA

Budapest, July 14, 2001

Luciano Maiani

CERN. Geneva



- "And so, " - Fermi came to his overwhelming question, -
"if all this has been happening, they should have arrived
here by now, so where are they ? "
- It was Leo Szilard, a man with an impish sense of humor,
who supplied the perfect reply to Fermi's rethoric: - "They
are among us," - he said, - "but they call themselves
Hungarians. " (F. Crick, quoted in G. Marx,
www.kfki.hu/~tudtor/tudos1/stocholm.htm)

The accelerator chain of CERN

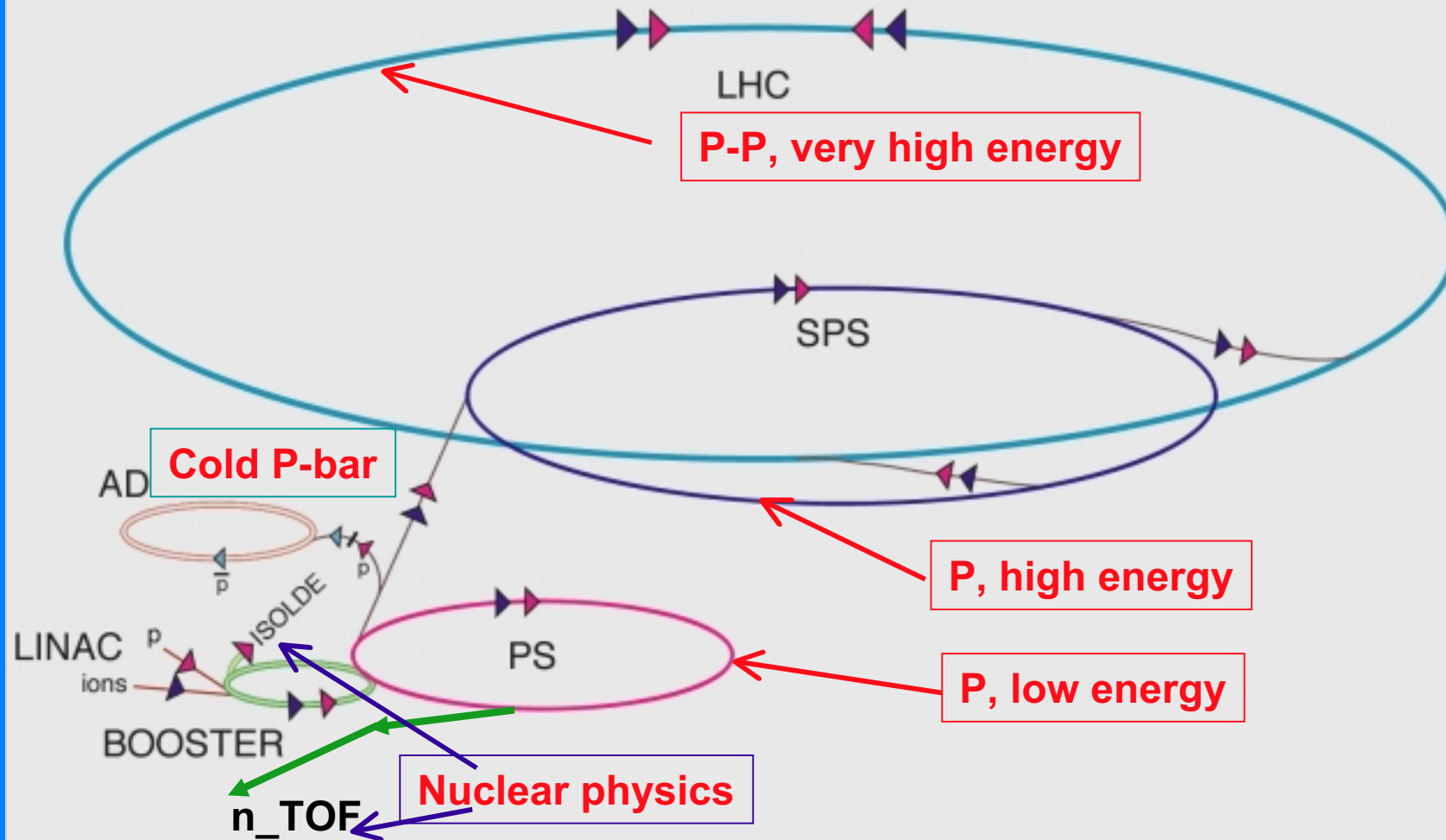

-
-
-

Summary

- LEP (almost) final analysis
- Fixed target experiments
- LHC status
- LHC computing
- Accelerator R&D
- Summing up



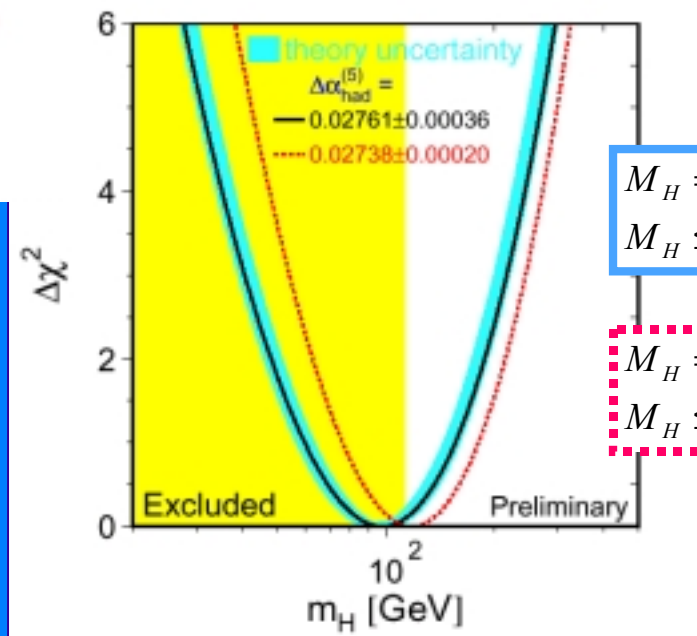
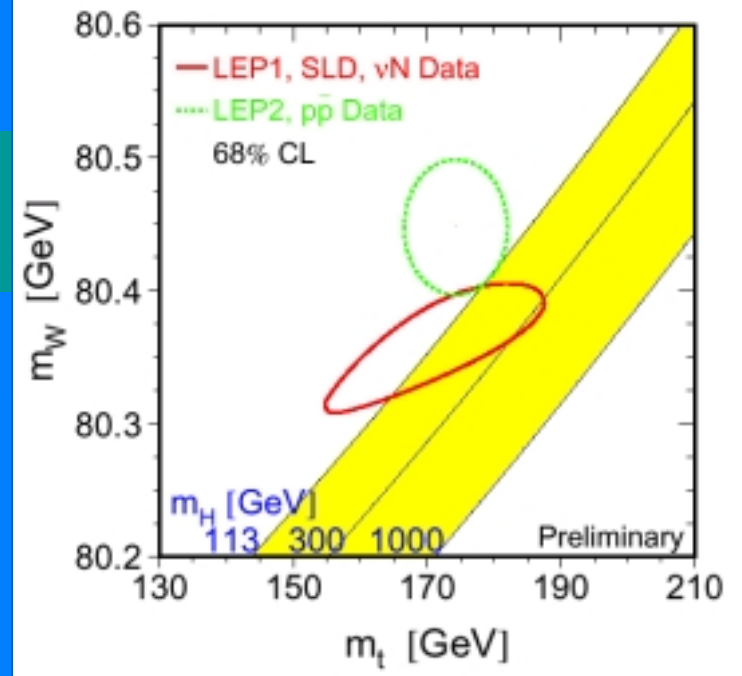
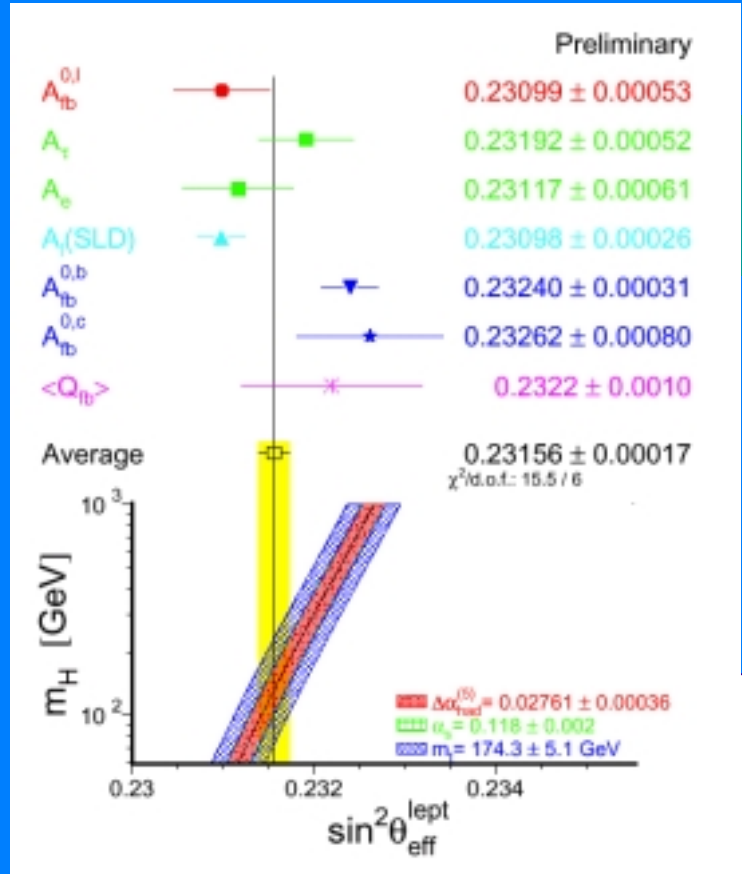

blueplot

$M_H = 98^{+58}_{-38}$
 $M_H \leq 212 \text{ GeV} (95\% \text{ - c.l.})$

$M_H = 118^{+63}_{-42}$
 $M_H \leq 236 \text{ GeV} (95\% \text{ - c.l.})$

Electroweak results
@LEP and elsewhere

- ALEPH, DELPHI, L3 and OPAL
- The LEP working group for Higgs boson searches

Nov. 3,
2000

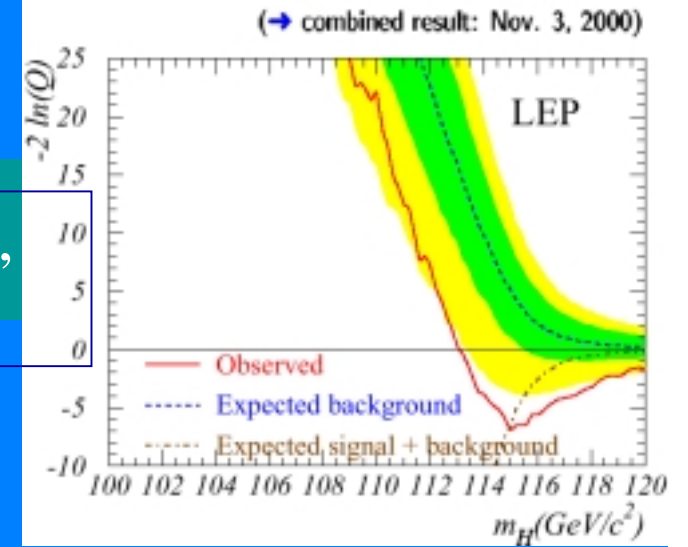
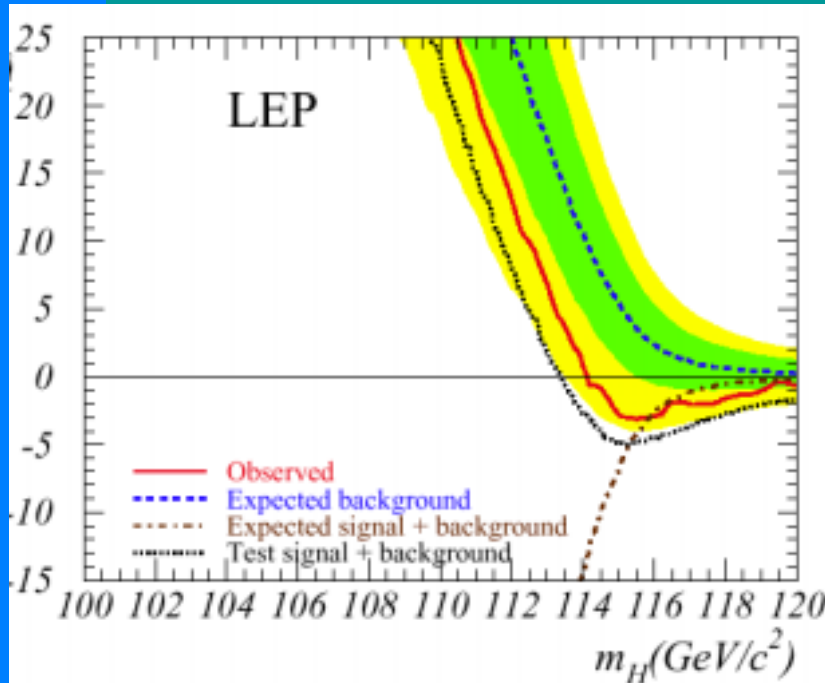

LEP Jamboree, July 10, 2001

- Minimum in agreement with σ (HZ) for: $m_H = 115.6 \pm 0.8 \text{ GeV}$
- Significance: 2.1σ

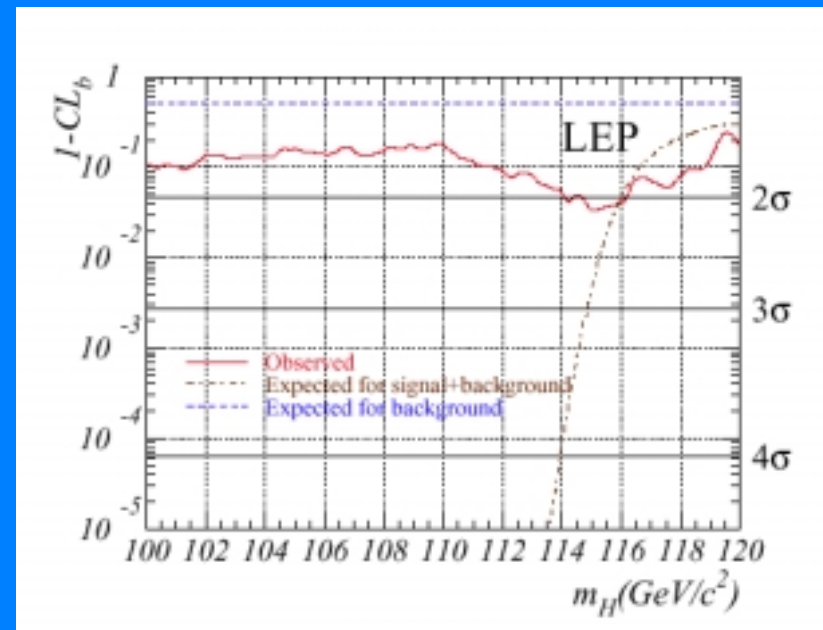

LEP working group for Higgs boson searches, July 10, 2001 (cont'd)

NOV. 3, 2000

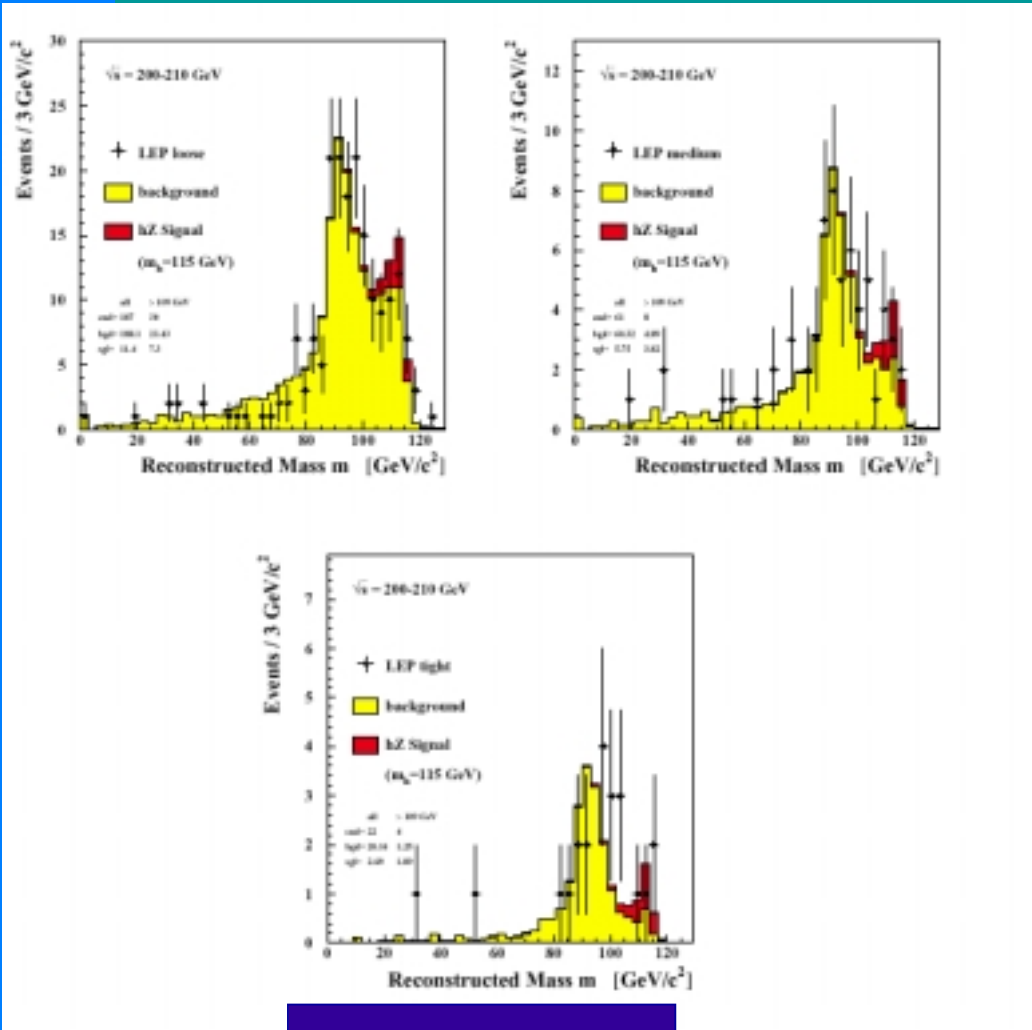

July 10, 2001

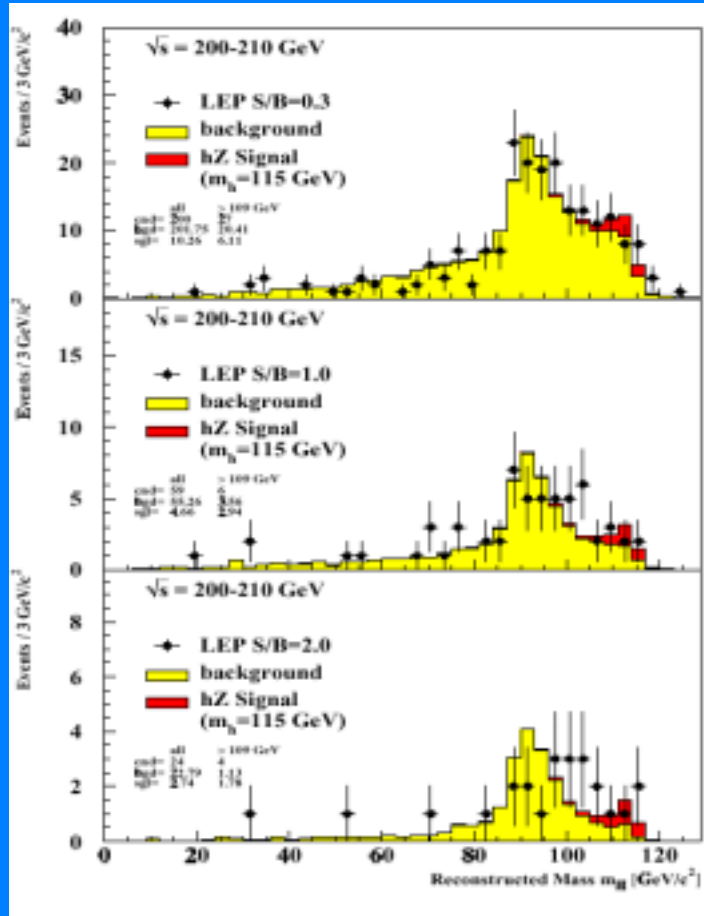

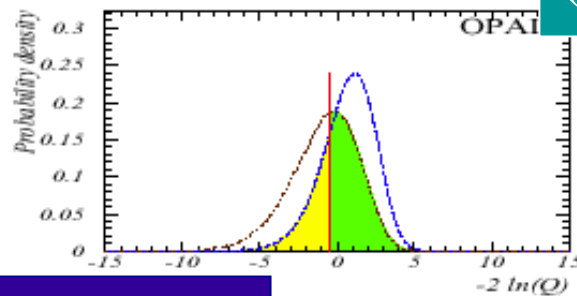
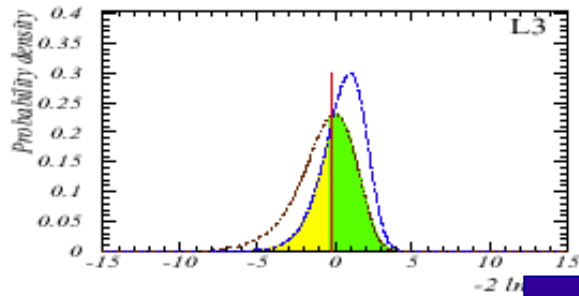
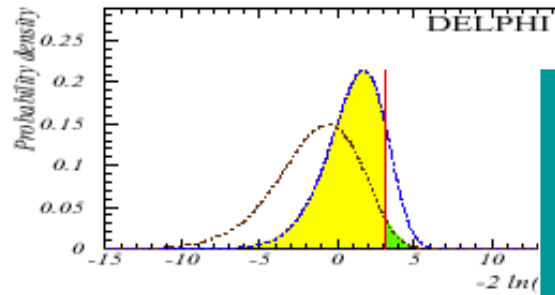
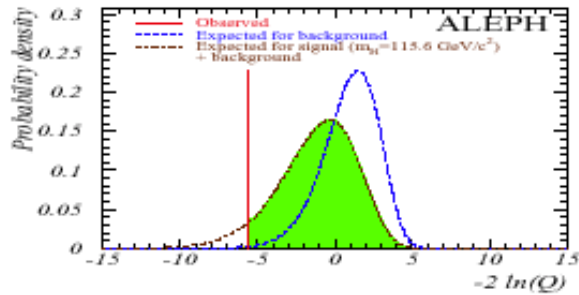

LEP working group for Higgs boson searches, (cont'd)

Nov. 3, 2000

July 10, 2001

for TOTAL data set, @ $m_H = 115$ GeV

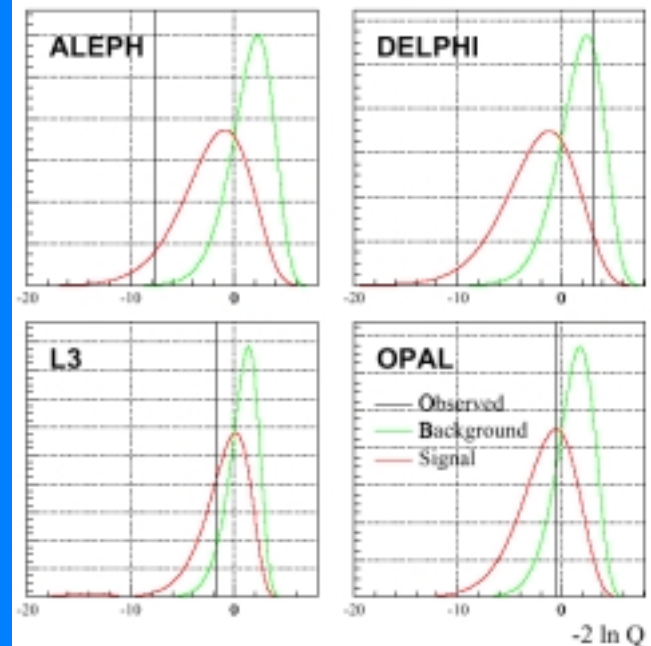

Hints of Higgs boson @115GeV persist !
 Anyway: $M_H > 114.1$ GeV
 Window for FermiLab
 Hunting ground for the LHC

Higgs Boson at the LHC

- SM Higgs boson can be discovered at $\approx 5\sigma$ after ≈ 1 year of operation (10fb^{-1} / experiment) for $m_H \approx 150\text{ GeV}$
- Discovery faster for larger masses
- Whole mass range can be excluded at 95% CL after ~ 1 month of running at $10^{33}\text{cm}^{-2}\text{s}^{-1}$.

results are conservative:

- no k-factors
- simple cut-based analyses
- conservative assumptions on detector performance
- channels where background control is difficult not included, e.g. $WH \rightarrow l\nu b\bar{b}$

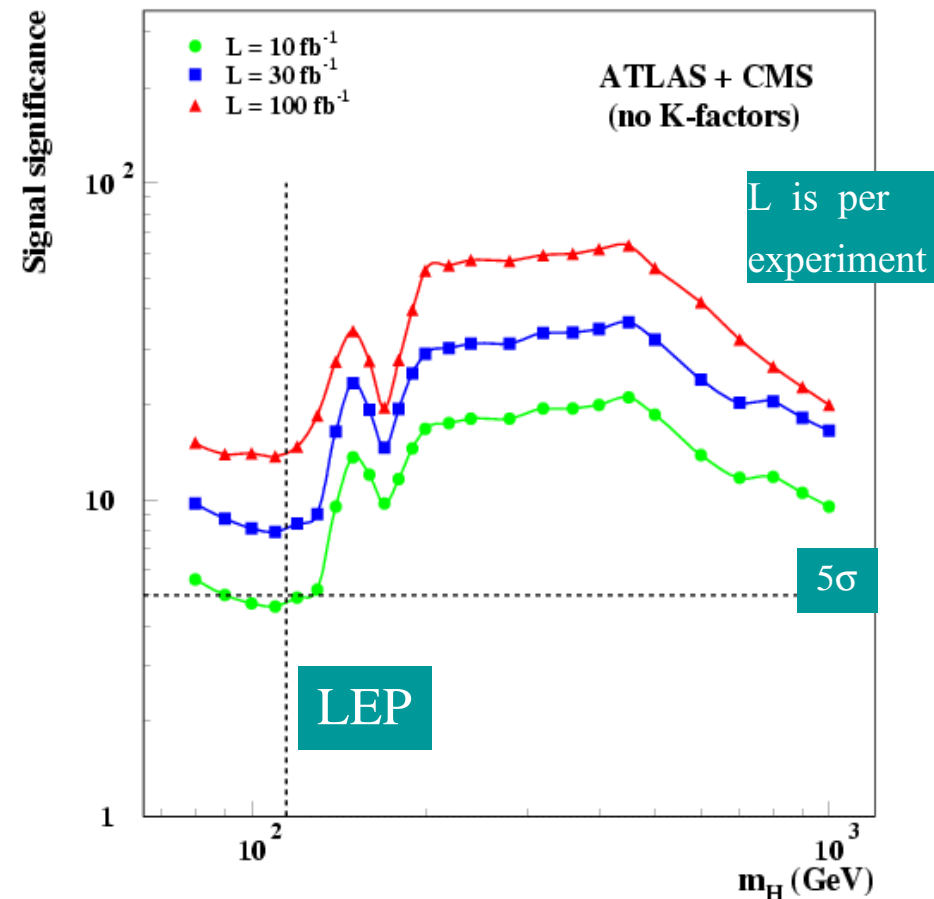

F. Gianotti

2. Fixed target

- NA48 (direct CP violation)
- COMPASS (muon DIS with polarised target)
- CNGS (neutrinos to Gran Sasso)
- HARP (low energy hadron production cross-sections)
- DIRAC (π^- π atoms)
- Antiproton Decelerator (ASACUSA, ATRAP, ATHENA)
- Nuclear Physics:
 - ISOLDE (radioactive beams, condensed matter physics),
 - n-ToF,
 - Heavy ions (transition to deconfined phase? to 2003)
- CAST (solar axions?)

THE SIMULTANEOUS K^+ AND K^- BEAMS

NA48 overview

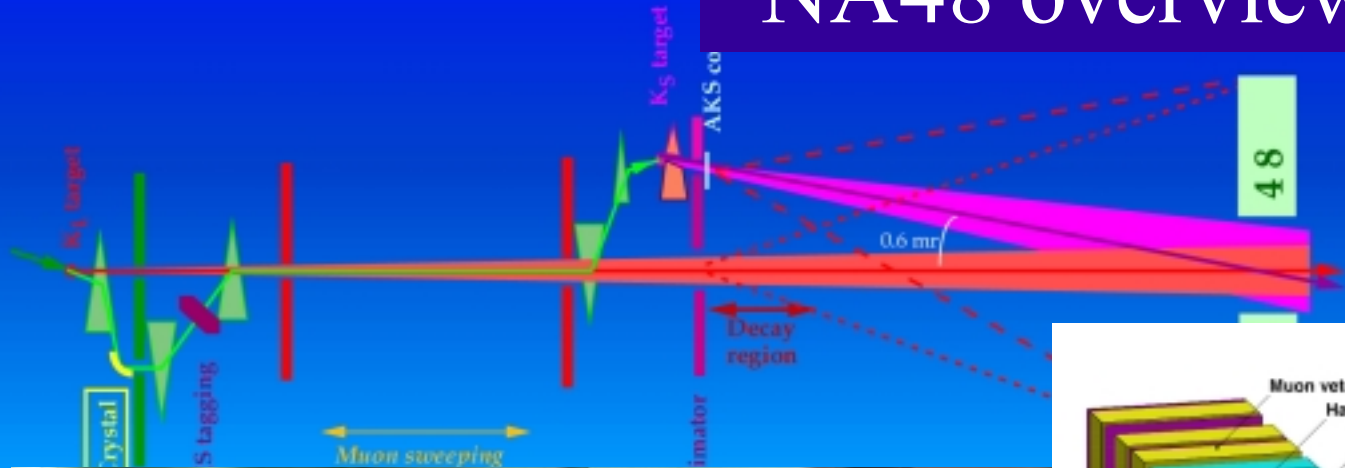

Liquid Kr Cal

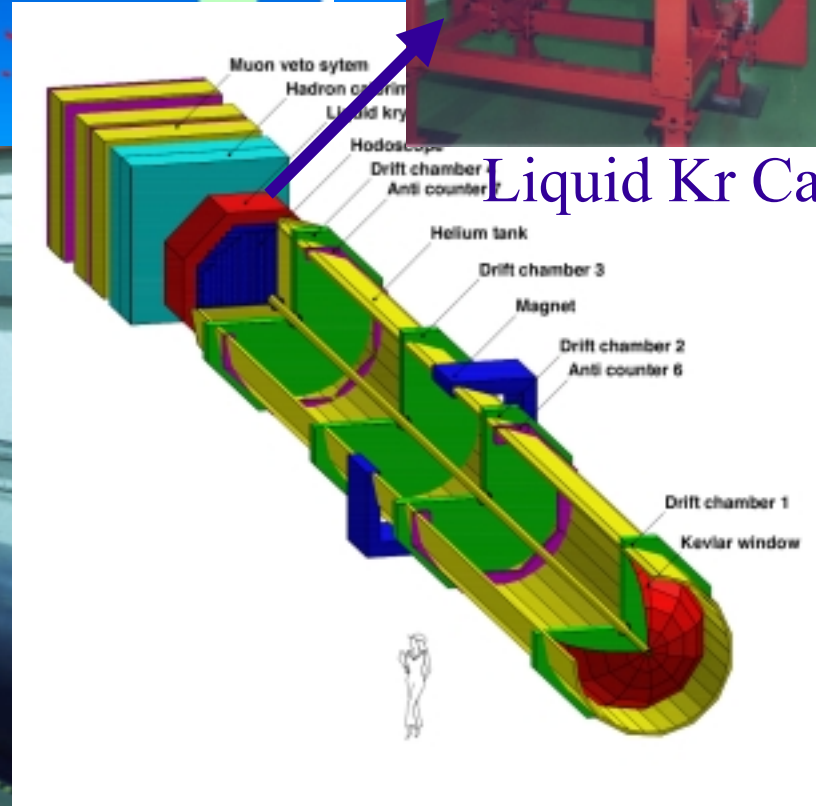

ϵ'/ϵ : - new (~final) result reported by NA48
 - KTeV and NA48 now consistent

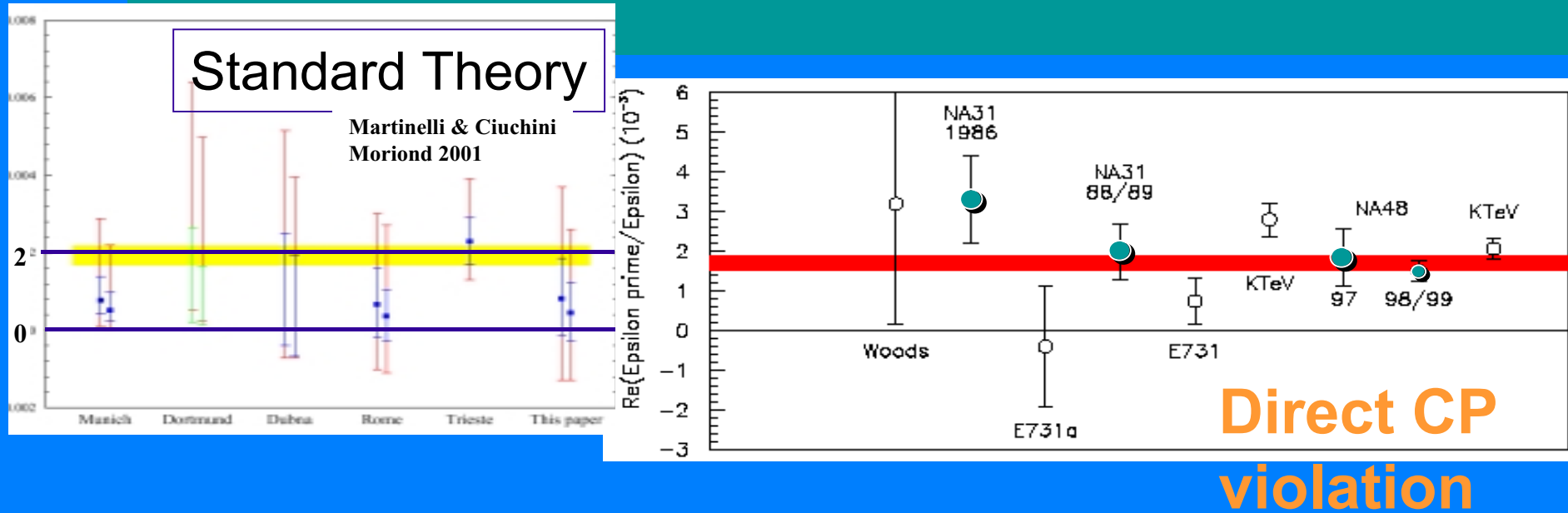

- **2002(NA48/1)** : $K_S \rightarrow \pi^0 + e^+ + e^-$ (CP even, determines mixing part of CP odd K_L decay)
- neutral hyperon decays ($3 \cdot 10^{10}$ neutral kaon decays);
- **2003 (NA48/2)** : high statistics study of CP violating slope in $K^\pm \rightarrow \pi^\pm + \pi^+ + \pi^-$ (to $O(10^{-4})$).

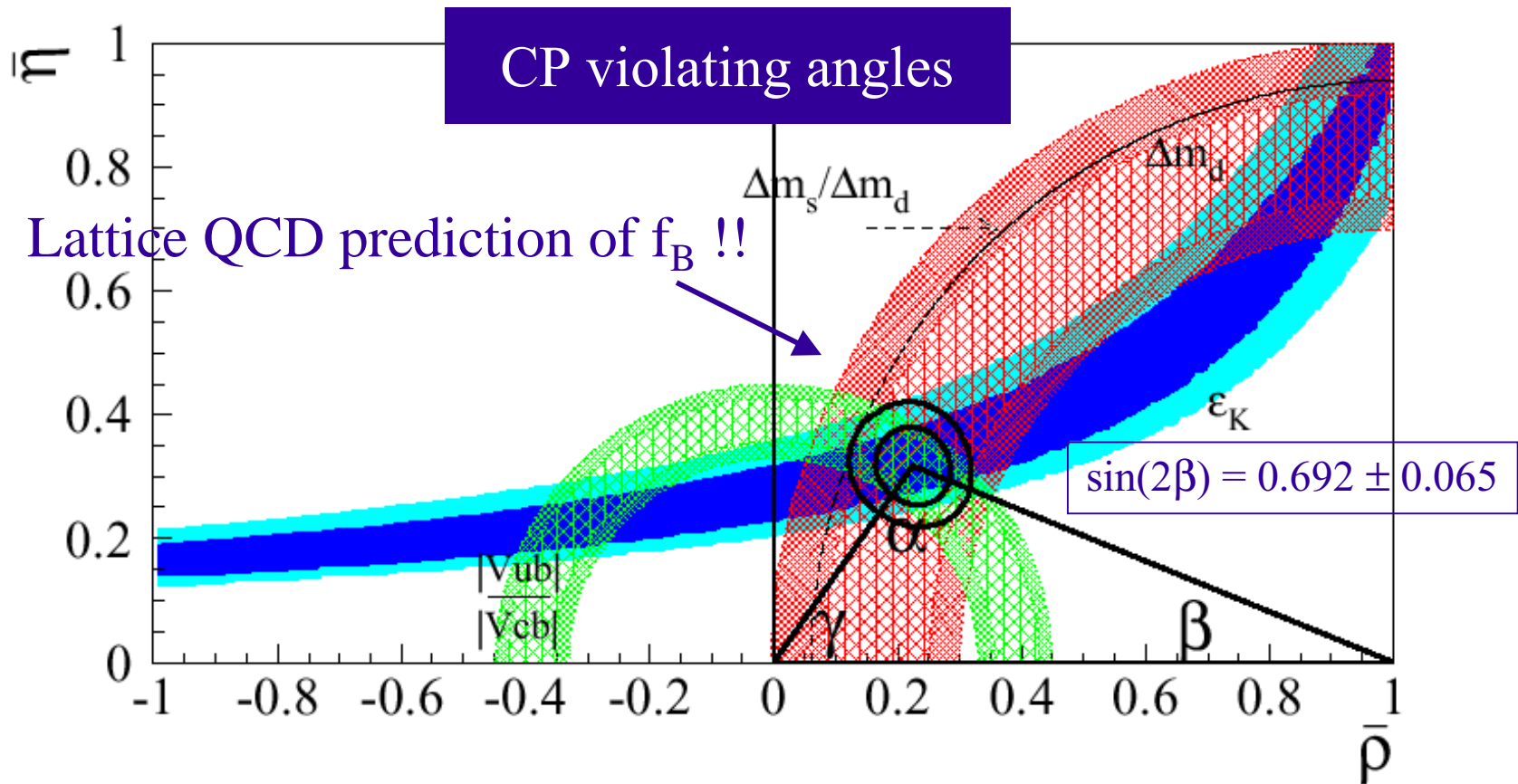

M. Ciuchini et al.
 arXiv: hep-ph/0012308 v3

BaBar:
 $\sin 2\beta = 0.590 \pm 0.14$ (stat) ± 0.05 (syst)
 Belle: ???

The allowed regions for ρ and η (contours at 68%, 95%) are compared with the uncertainty bands (at 68% and 95% probabilities) for $|V_{ub}|/|V_{cb}|$, $|\epsilon_K|$, Δm_d and the limit on $\Delta m_s/\Delta m_d$ (dotted curve).

• Long-Baseline Neutrino Programme: CNGS

- To observe the appearance of tau leptons;
- complementary to the lower-energy K2K (Japan) and to MINOS (US) focussed on ν_{μ} disappearance;
- OPERA approved by the CERN Research Board and by INFN (Jan. 2001);
- CERN will support a in-house group in OPERA, building on the experience accumulated in CHORUS and NOMAD.

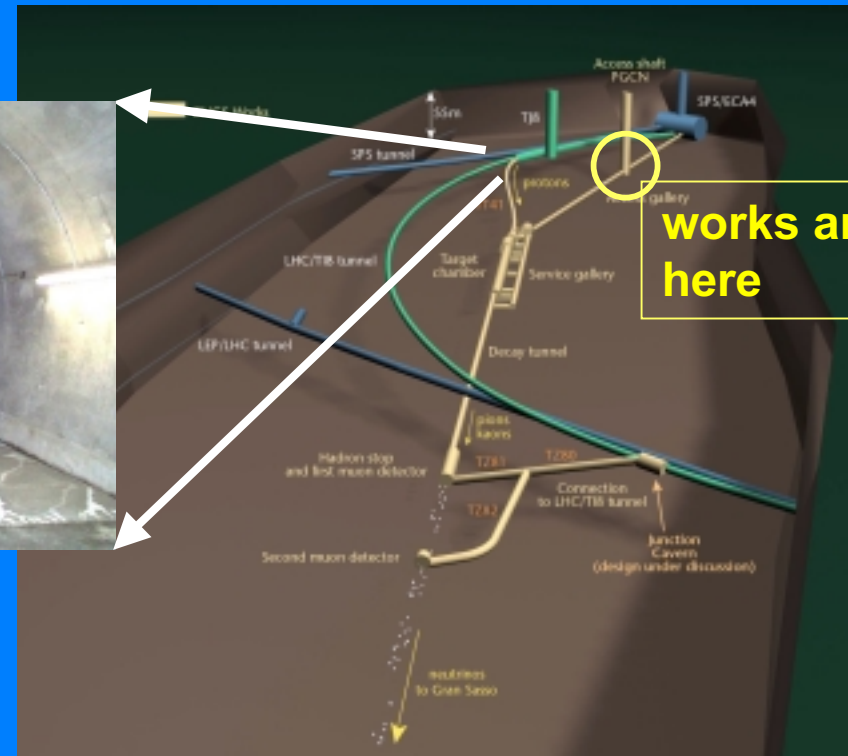
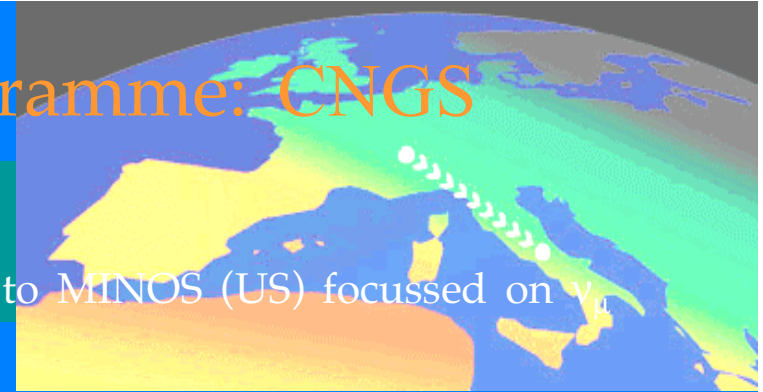



Tunnel boring for CNGS



Antiproton Decelerator

Collects antiprotons at 3.6 GeV/c and decelerates them to 100 MeV/c

Beam parameters at 100 MeV/c

	Achieved	Design
Fluence antiprotons / s	2.4×10^5	1.7×10^5
Antiprotons per pulse	2.7×10^7	1.2×10^7
Repetitions time	110 s	60 s



The First PRL from CERN AD

Antiproton mass (M) & charge (Q) CPT limit from ASACUSA (antiprotonic helium "atomcule")

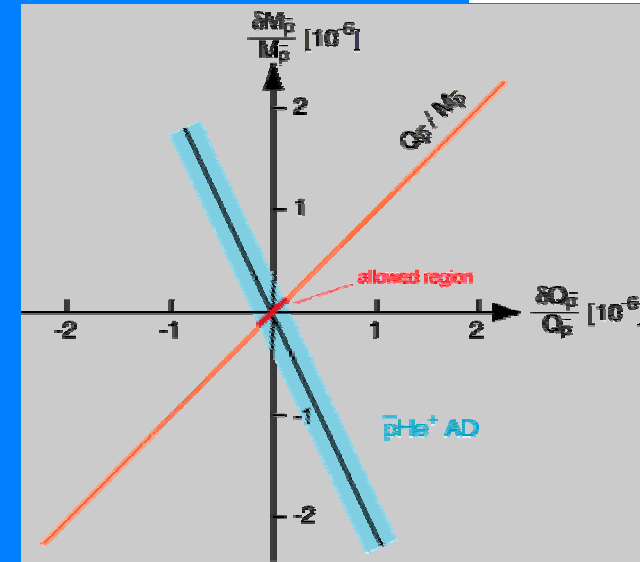
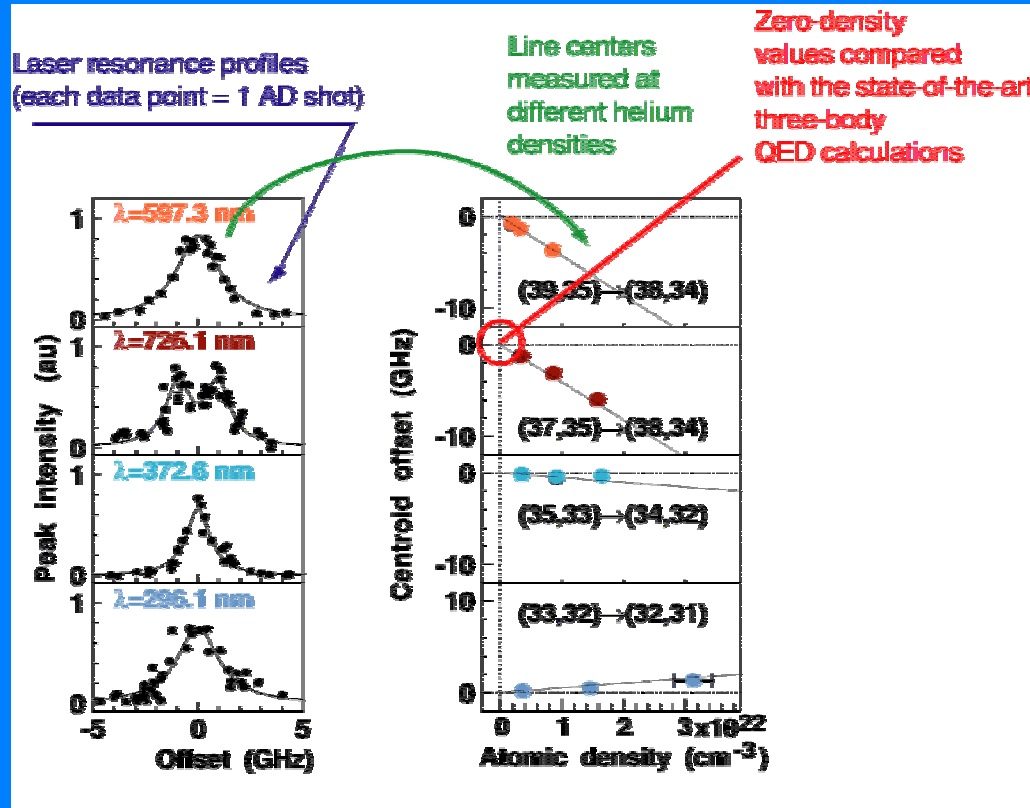
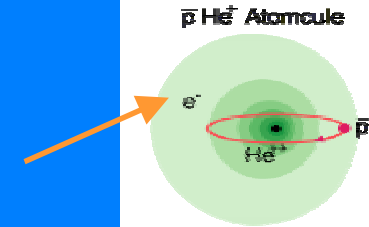

- ASACUSA measures antiprotonic "Rydberg" MQ^2
- Combine this with the Q/M measured to 9×10^{-11} at LEAR (Penning trap) → a new CPT limit of antiproton mass (M) and charge (Q) of <0.00000006

x 300 improvement over X-ray measurement
 x 10 improvement over LEAR PS205 result

ATRAP: cooling antiprotons with positrons

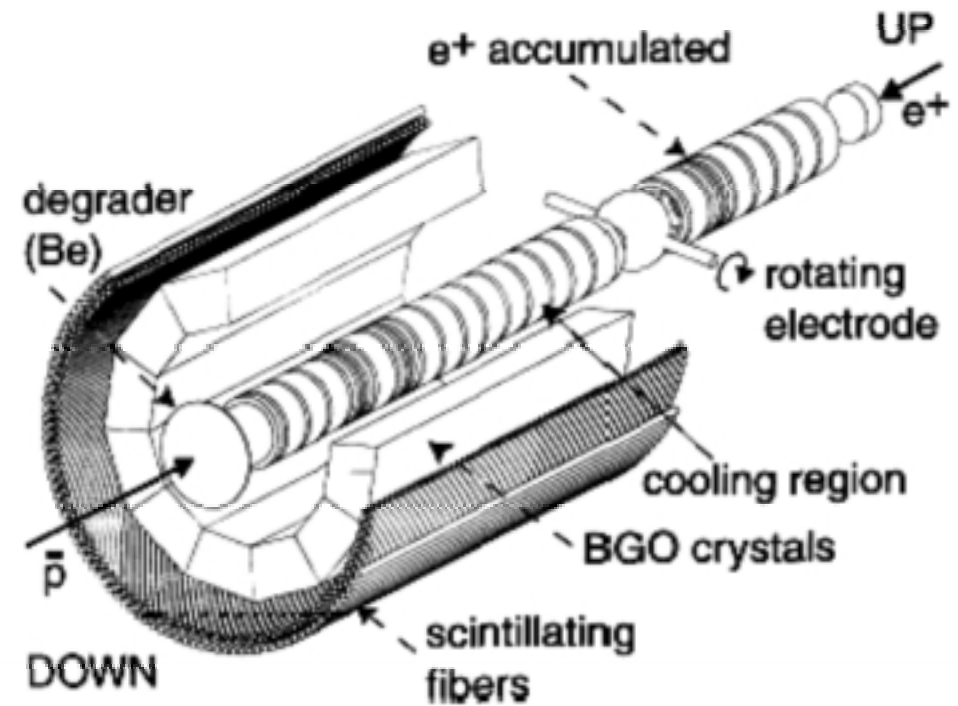
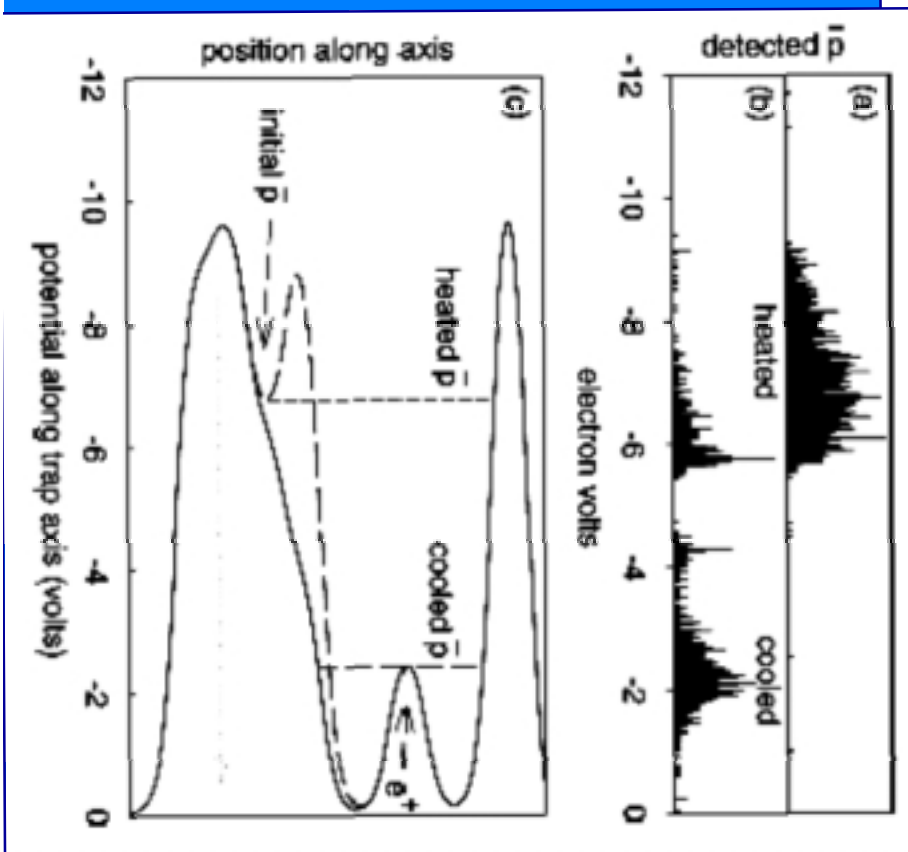

Achievements 2001

- Captured + cooled antiprotons
~ 15,000 /AD shot ✓
- Accumulate positrons
~ 30 million in 60 sec ✓
- Transfer positrons
> 50 % efficiency ✓
- Detect annihilation of
 - antiprotons ✓
 - positrons ✓

ATHENA is ready for ANTIHYDROGEN PRODUCTION in August 2001

Pulsed recombination scheme

Move antiprotons through positron plasma with high repetition rate at low relative energy (< 0.1 eV)

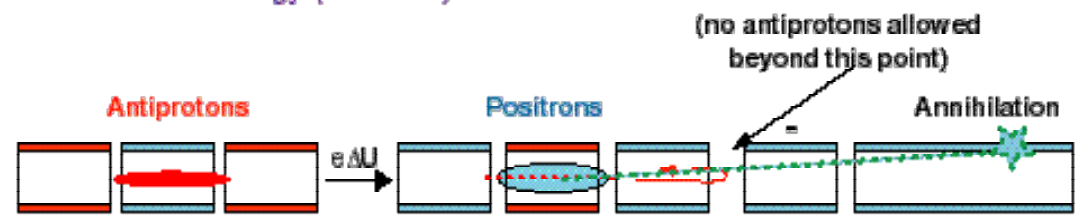

Annihilation Detector for charged particles and gammas

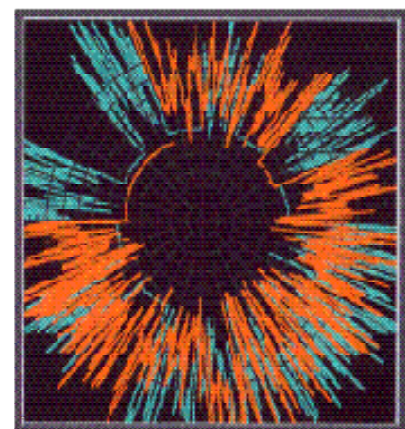

Detection of several hundred antiprotons annihilating during the capture from the AD into the Penning trap (orange: inner layer; blue: outer layer)

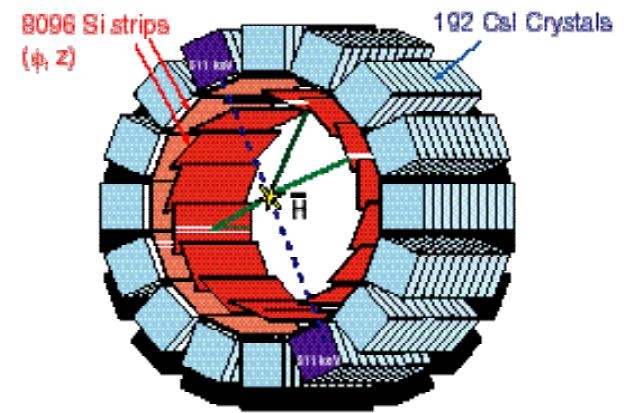

Antihydrogen signature:
 Simultaneous annihilation of antiproton and positron at same position
 (Beware of positron background from π^0 conversion!)

Neutron Time of Flight facility

Intense beam of neutrons:

$\Phi > 7 \cdot 10^5 \text{ n/cm}^2 \text{ /pulse}$

- $E = 0.1 \text{ eV to } 100 \text{ MeV}$;

- $\Delta E/E = 7 \cdot 10^{-5}$ (by ToF determination);

A rich physics programme

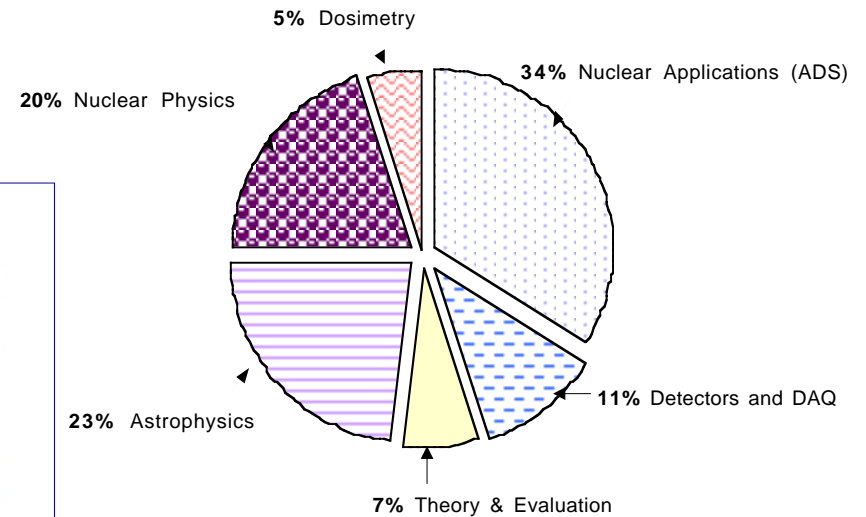
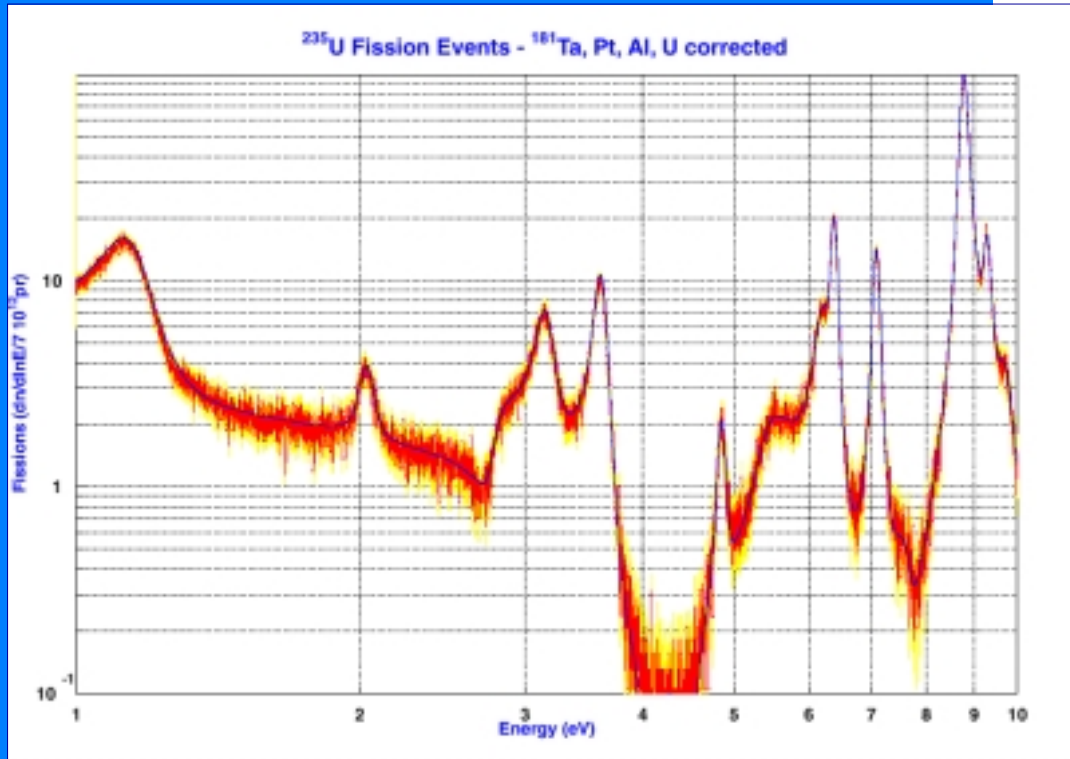

Research Activities of the N-ToF Collaboration

Fighting with background...

Civil engineering status - underground

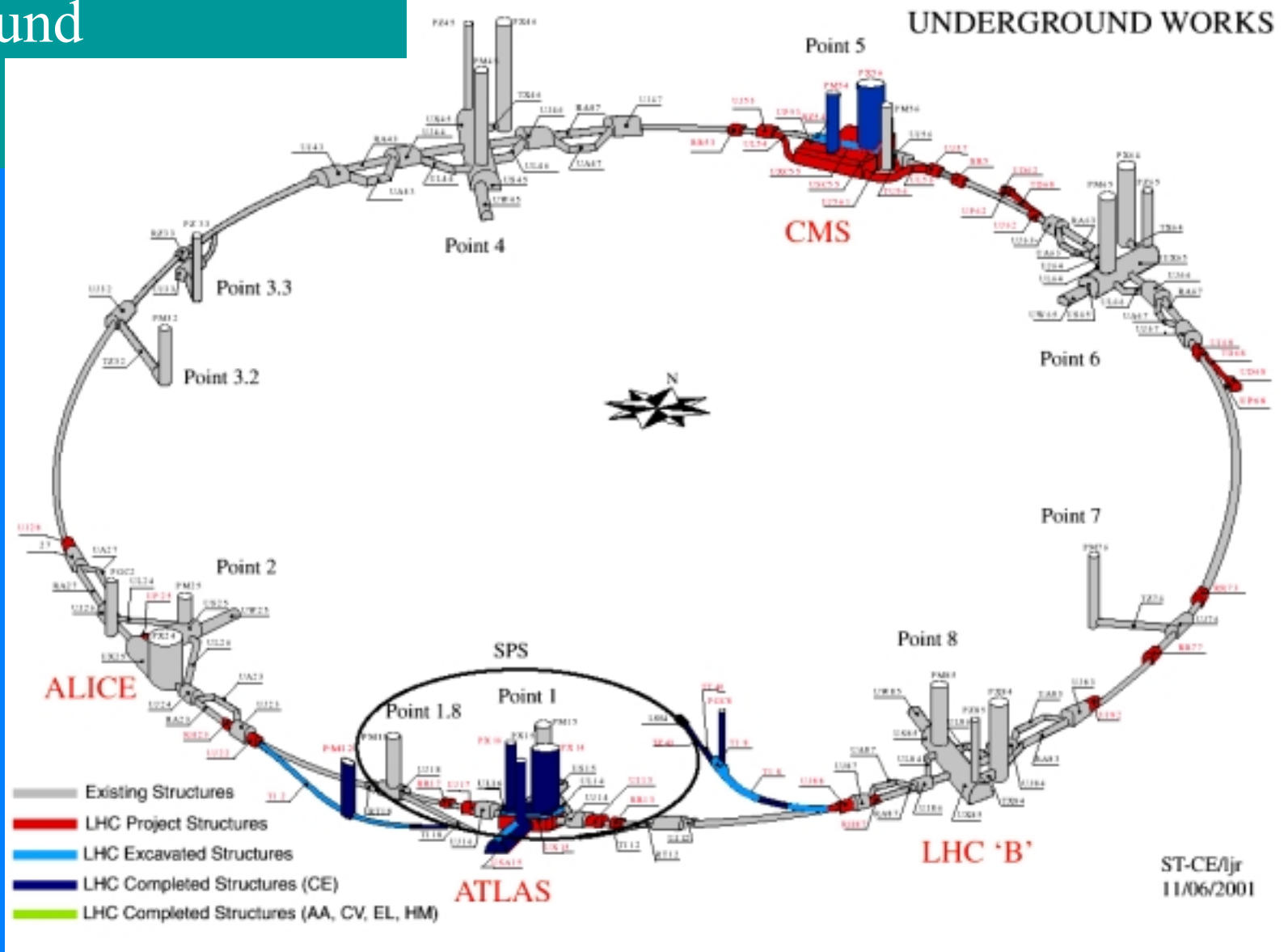

Civil engineering - TI2



Breakthrough of tunnel TI2 into the LEP near Point 2



LEP dismantling status (29.06.01)



Machine: >50% dismantled
end of works \approx March 2002

Indicateurs d'évolution du démantèlement LEP

09/07/2001 08:00

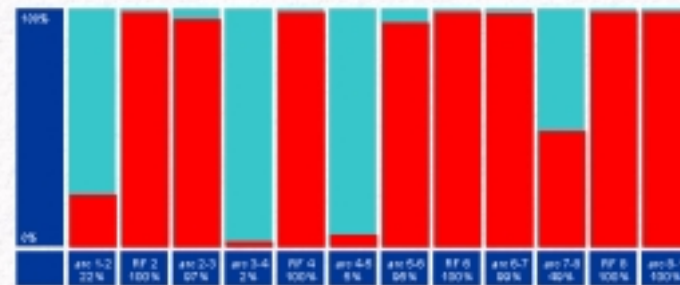

CMS cavern (Point 5)

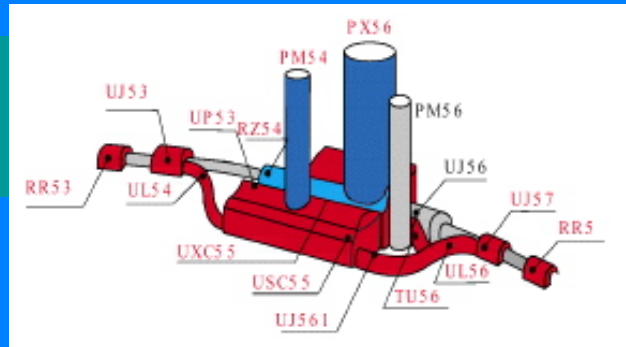
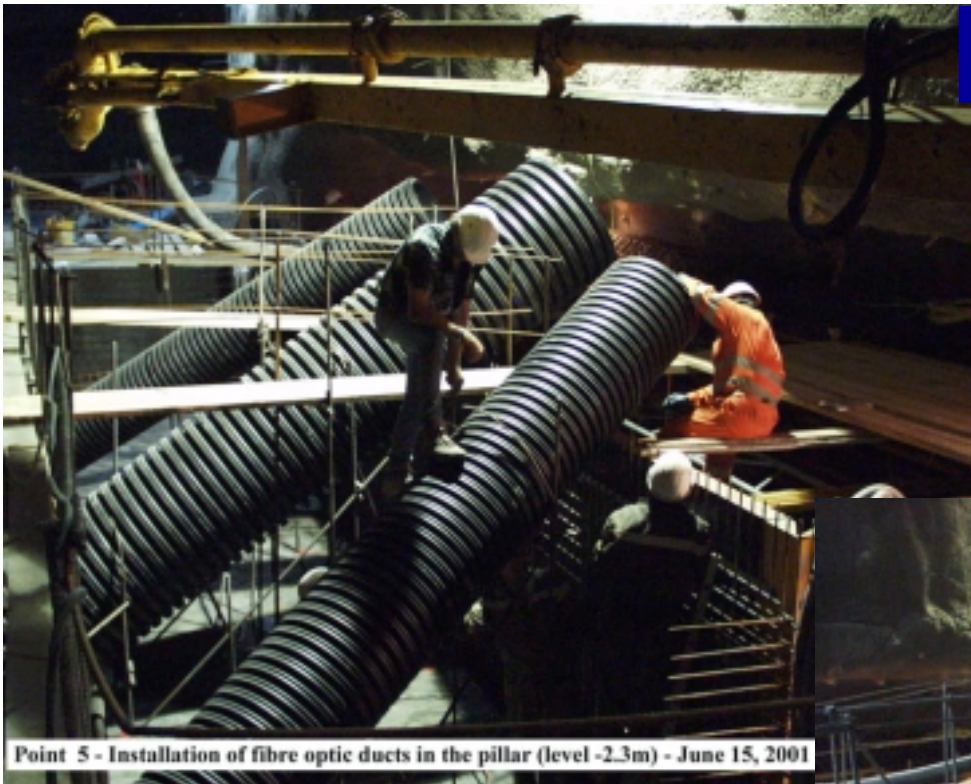

Pillar concreting ends in August 01
Cavern excavation starts



-
-
-

The LHC dipoles n. 0002 and 003

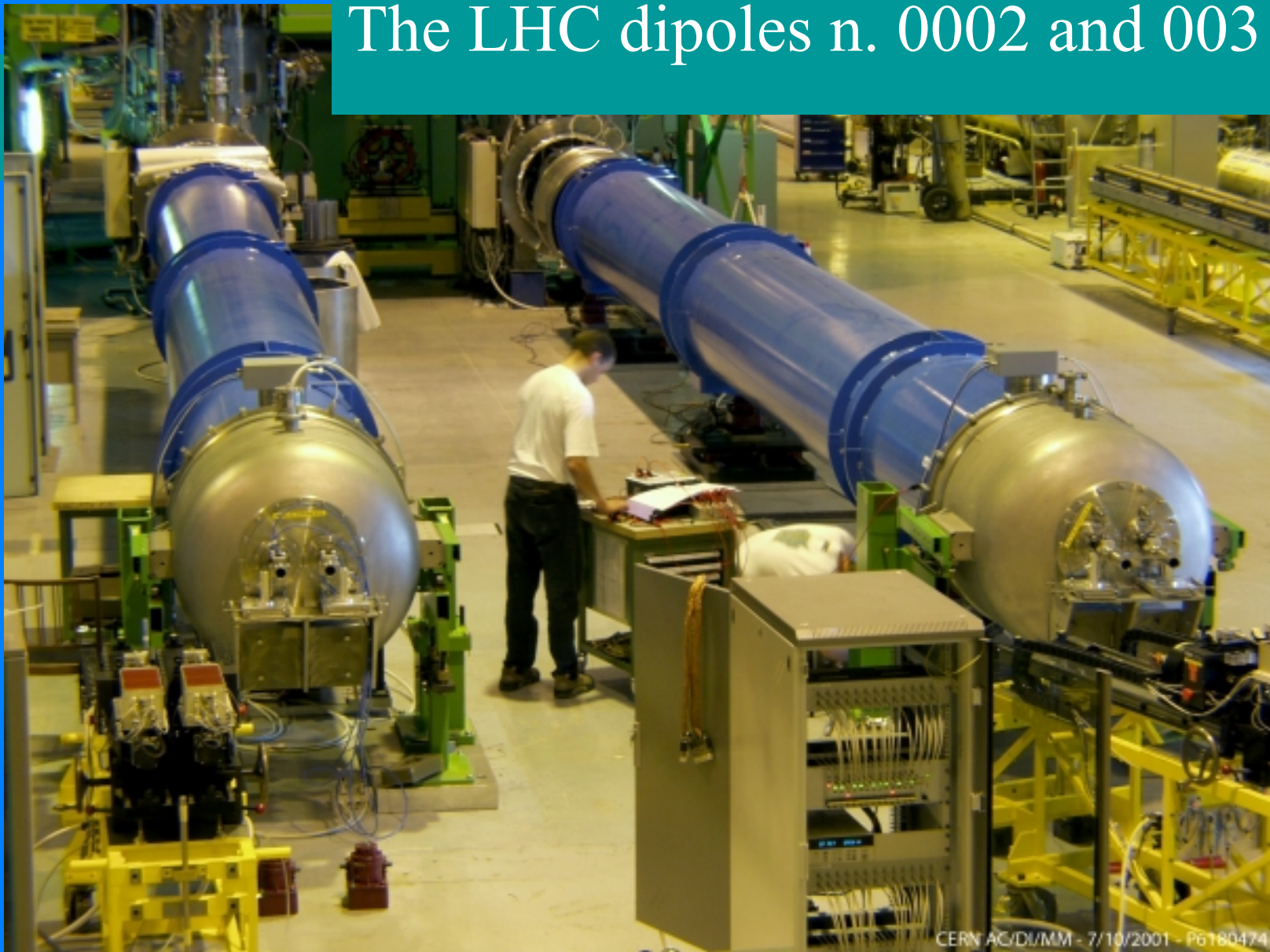

Series dipole #1

Training Curves

Training Quenches at 1.8K

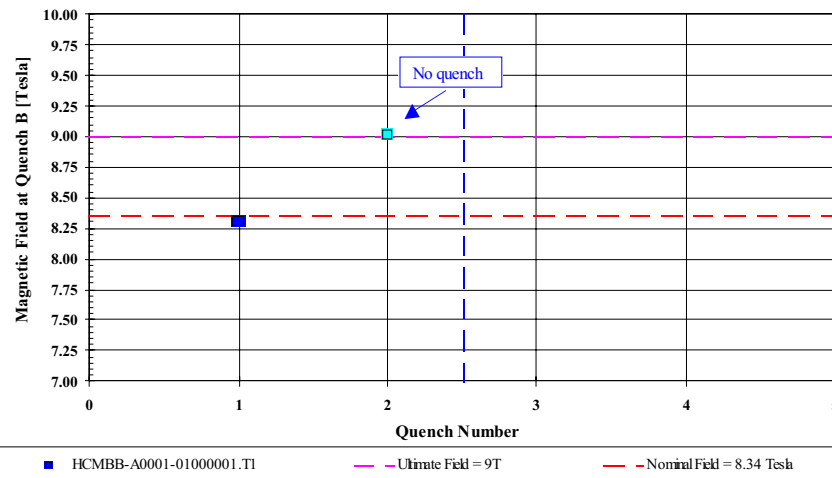

Series dipole #2

Training Quenches at 1.8K

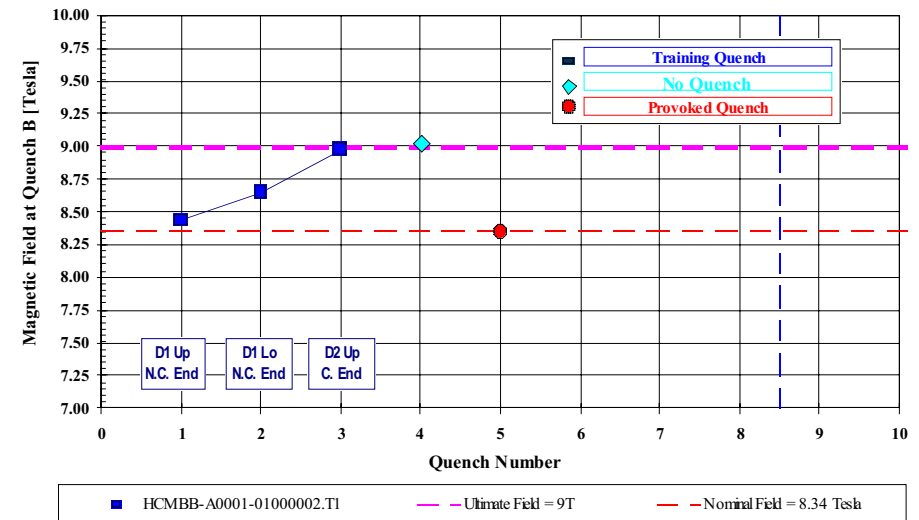

Dipole tested in June 2001 - A. Siemko/LHC-MTA

A. Siemko/LHC-MTA

String 2



Being cooled now !

Magnets

Name	Quantity	Purpose
MB	1232	Main dipoles
MQ	400	Main lattice quadrupoles
MSCB	376	Combined chromaticity/ closed orbit correctors
MCS	2464	Dipole spool sextupole for persistent currents at injection
MCDO	1232	Dipole spool octupole/decapole for persistent currents
MO	336	Landau octupole for instability control
MQT	256	Trim quad for lattice correction
MCB	266	Orbit correction dipoles
MQM	100	Dispersion suppressor quadrupoles
MQY	20	Enlarged aperture quadrupoles

In production

Sound design, call for tender out now
Concern: sc cable production rate

Non-member States - Russian Federation

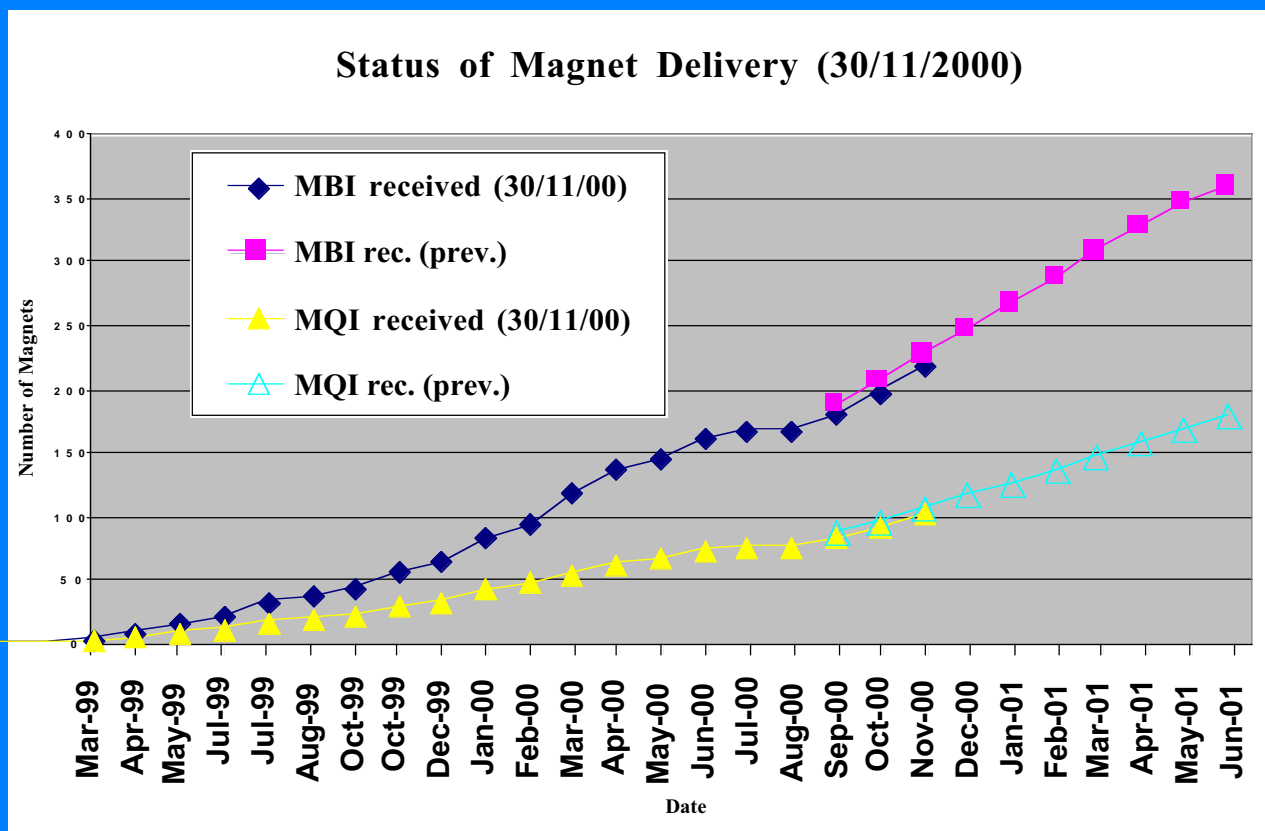

Dipole n. 360 in Novosibirsk

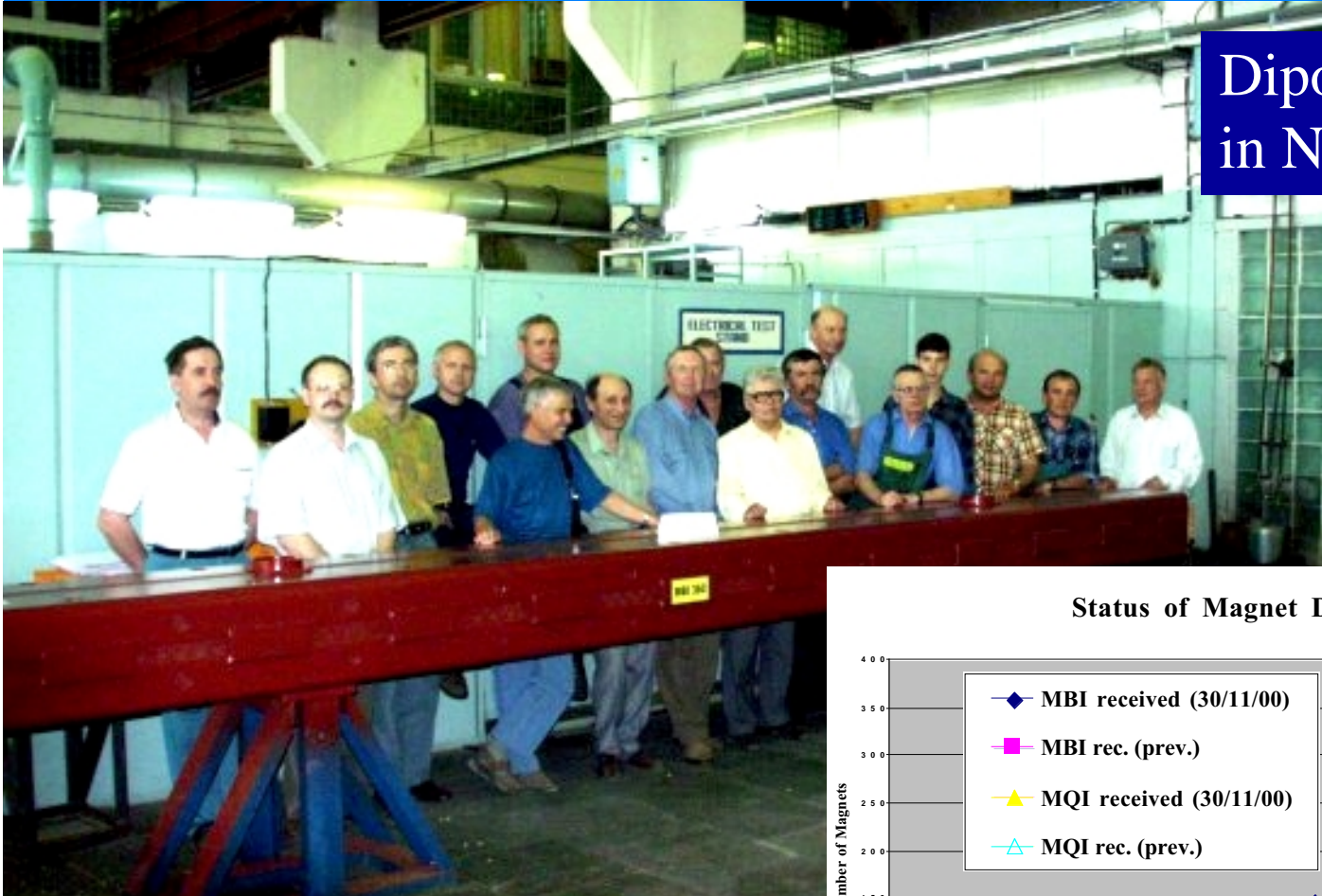

360 !

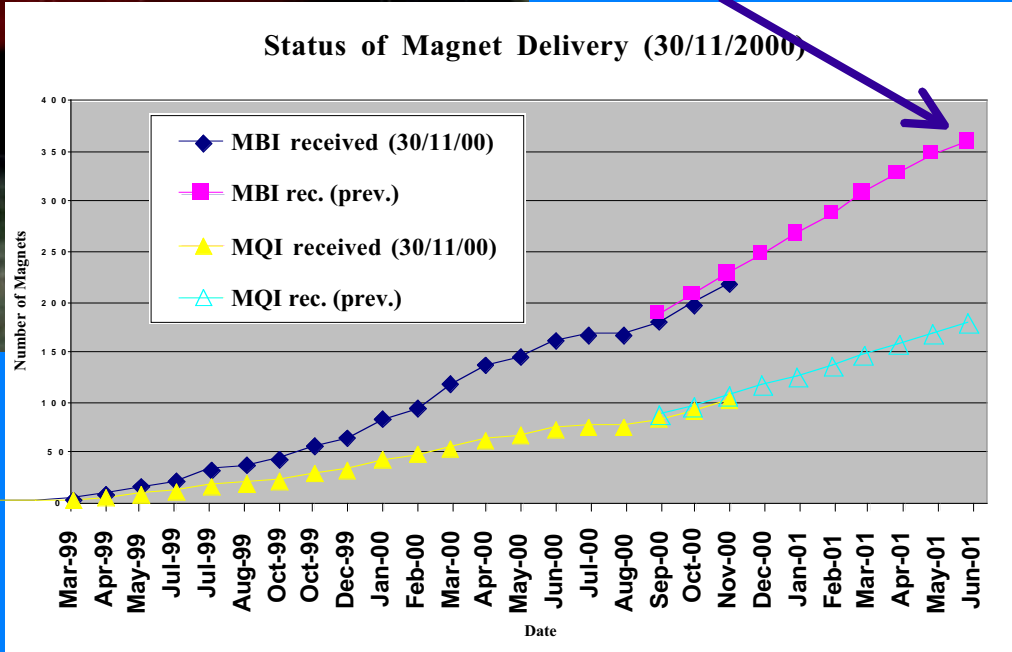

CMS: Surface and Underground Installations

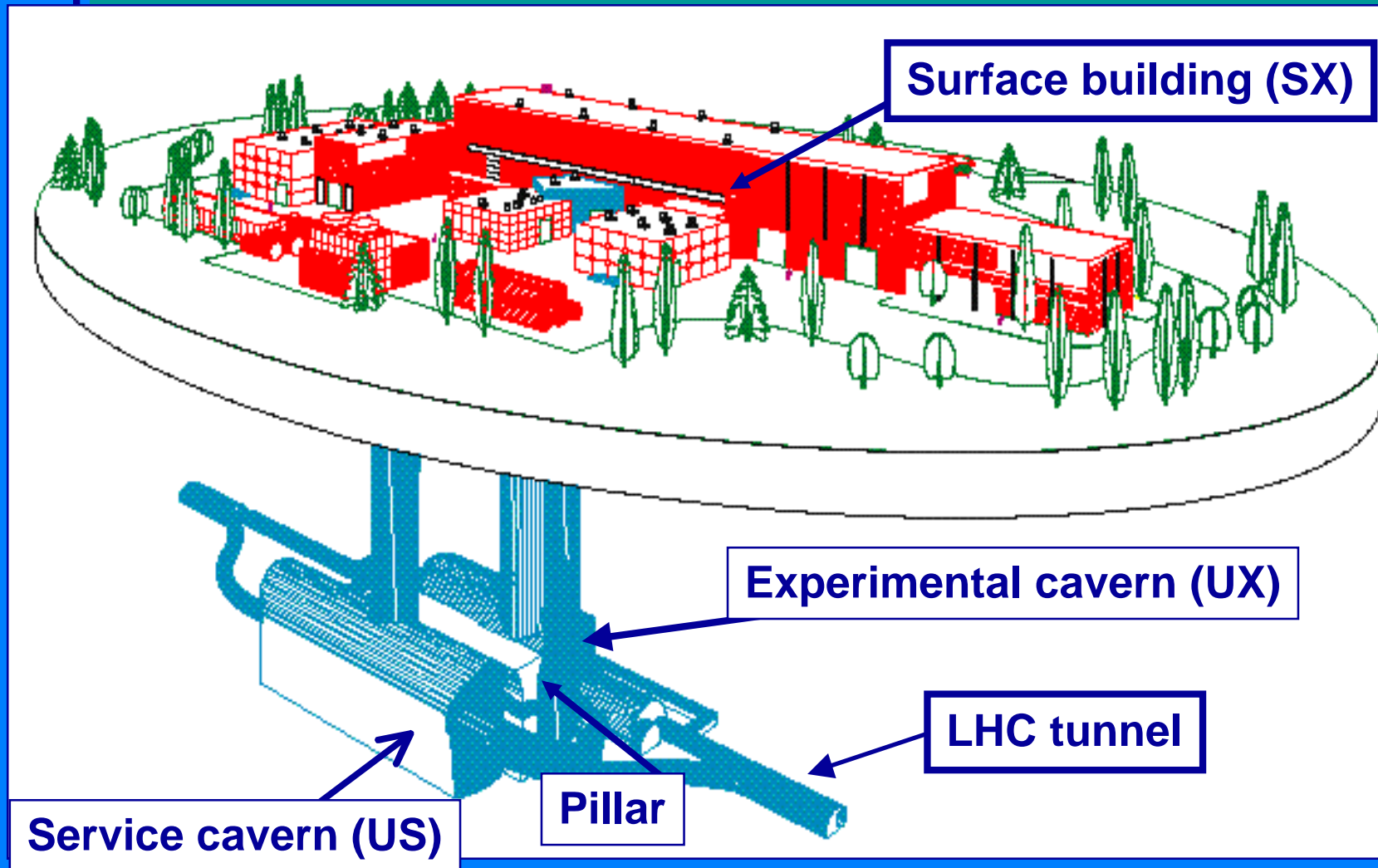

CMS Milestone Monitoring: update March 2001

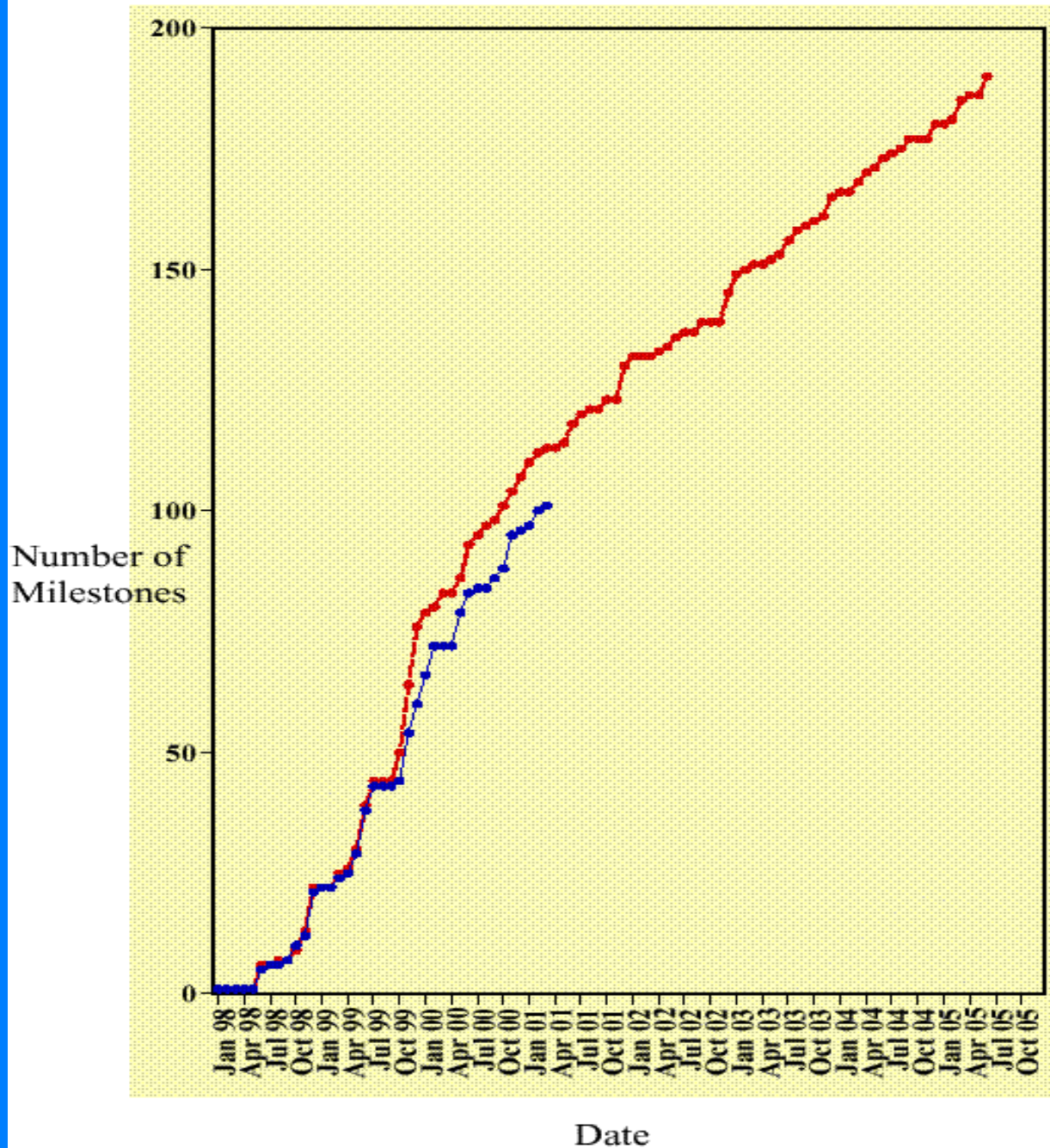

89% of the L1/L2 V26 Milestones are complete.

CMS can have the complete detector for the physics run starting August 2006, except for the 4th Endcap Muon station ME4, which is staged.

The limitation comes essentially from funding shortfalls or cash flow problems.

Magnet Yoke

YE-1 & nose trial assembly Nov '00
In Kawasaki (Japan)

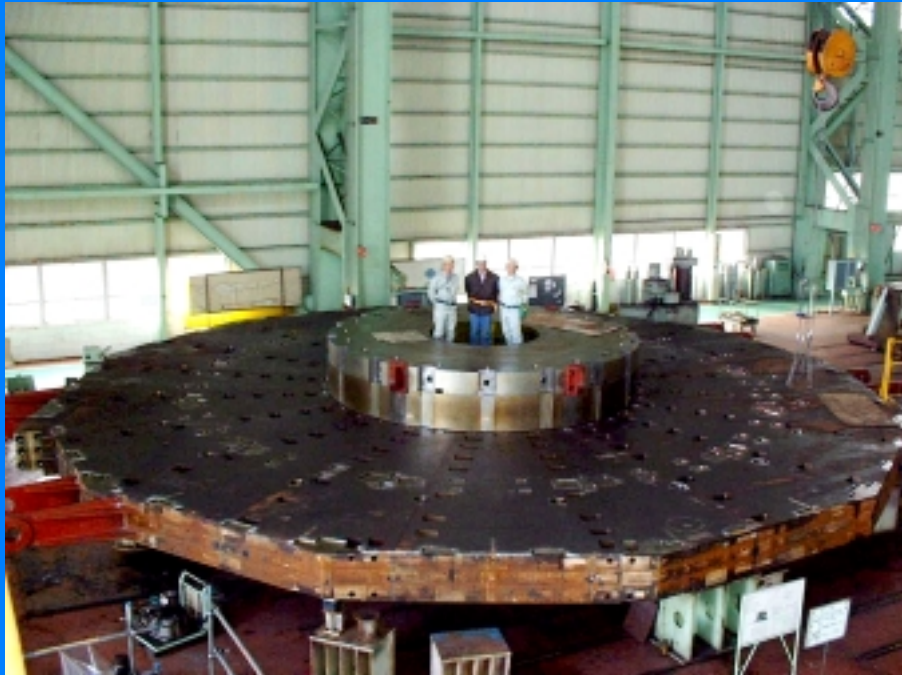

YB-2, YB-1, YB0 ready, YB1 started.
Central wheel YB0, supporting the
vacuum tank. **Web camera:**
<http://cmsdoc.cern.ch/outreach/>



ATLAS Milestones

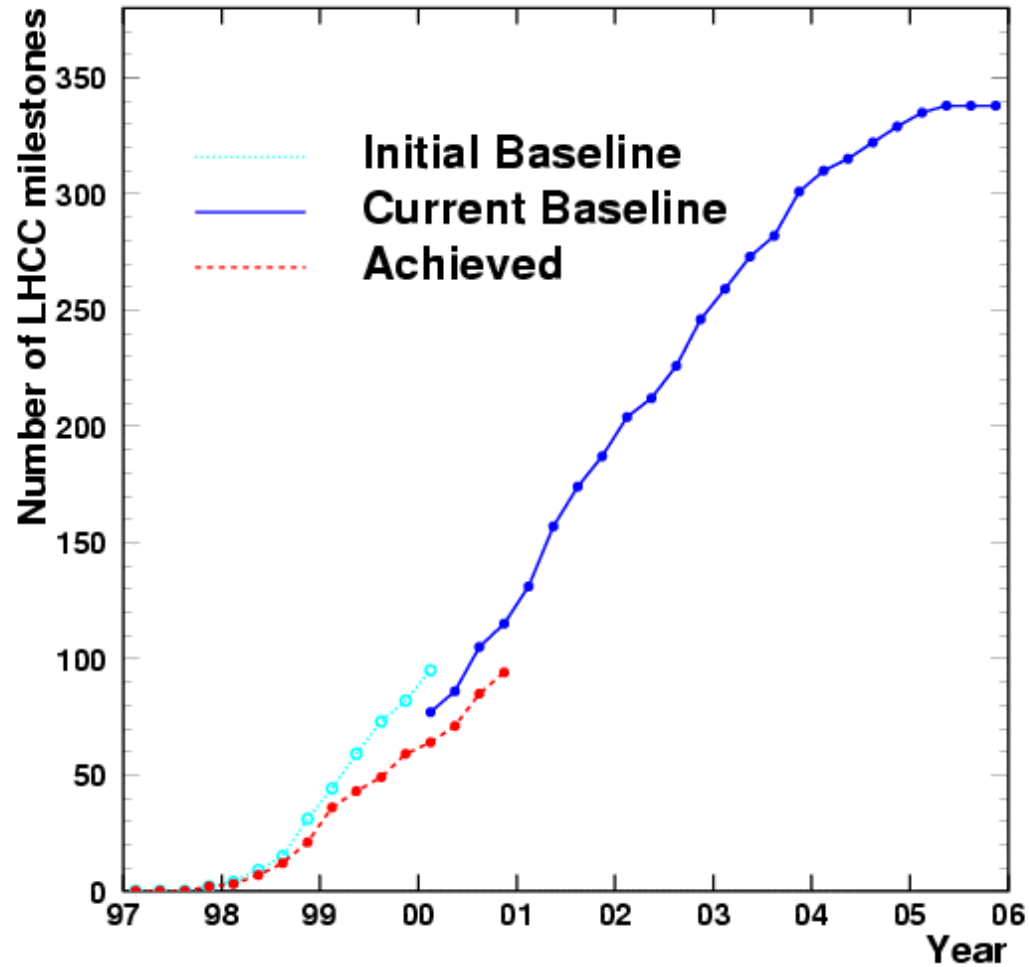



Completed solenoid and cryogenics chimney during tests at Toshiba (for KEK)

L. Maiani, 3/09/2000

Plenary ECFA

36

-
-
-



B0 coil connected to the barrel toroid test stand in Hall 180 at CERN

L. Maiani, 3/09/2000

Plenary ECFA

37

-
-
-
-
-
-
-
-

The *LHCb* Experiment



Brazil



Finland



France



Germany



Italy

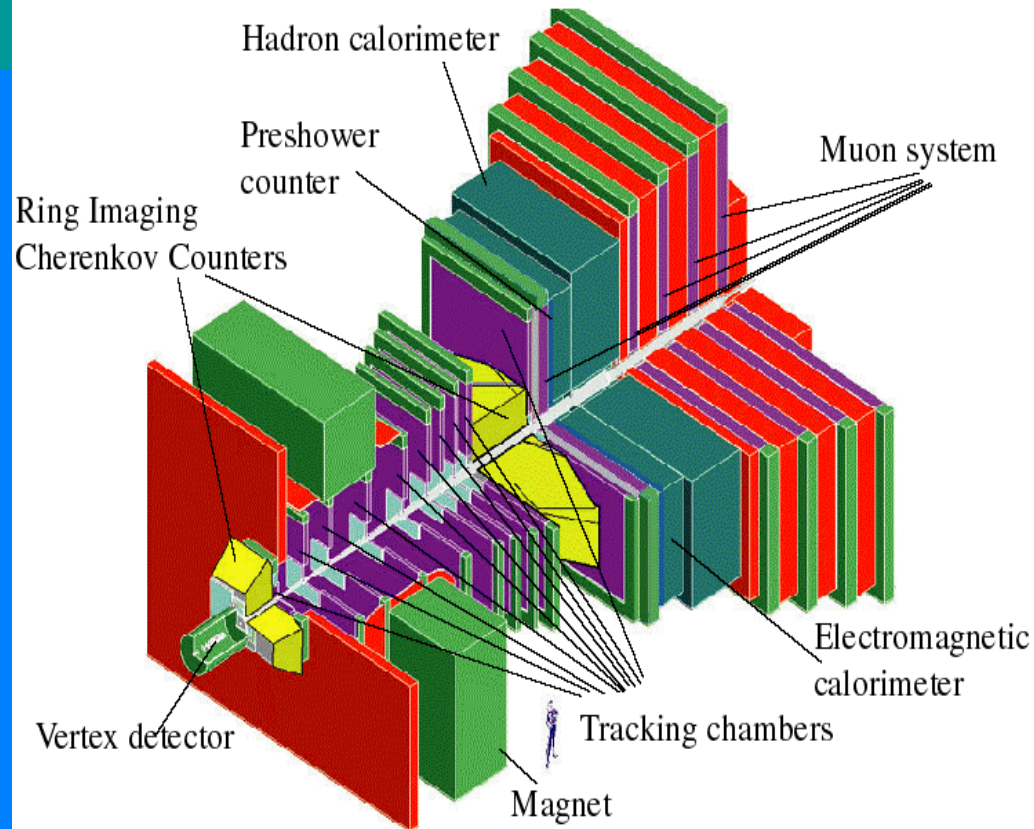

Ukraine



UK



Switzerland



Spain



Poland



PRC



Netherlands

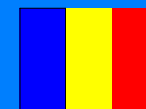

Romania



Russia

VELO mechanics \Rightarrow closely linked to the machine

Openings for
feedthrough
flanges
(25'000 pins)

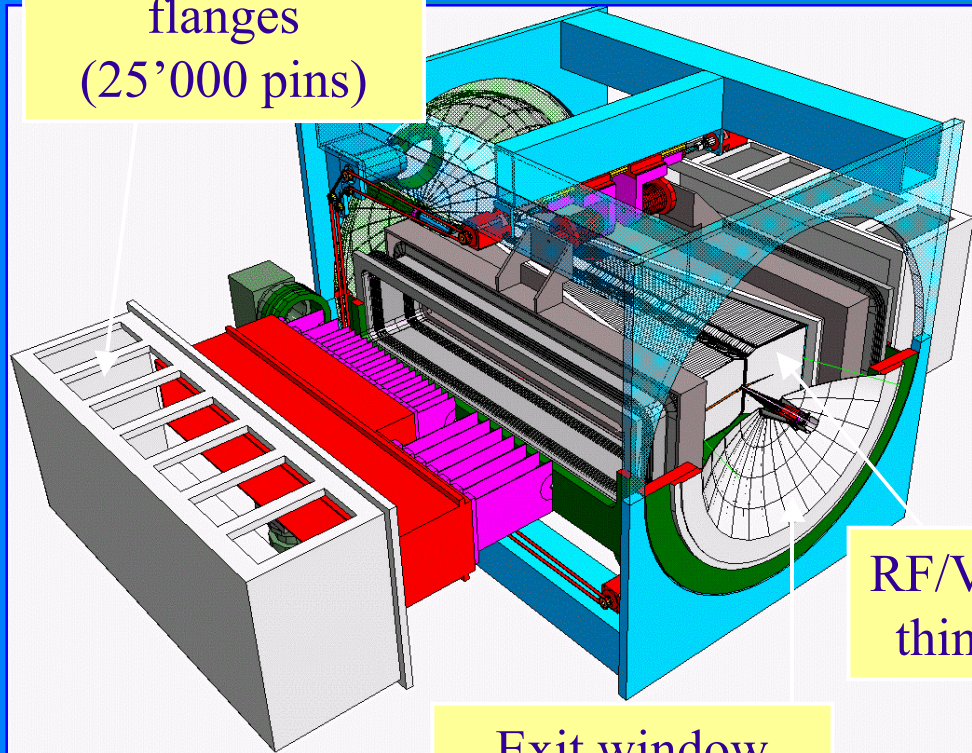

Vertex
detector half

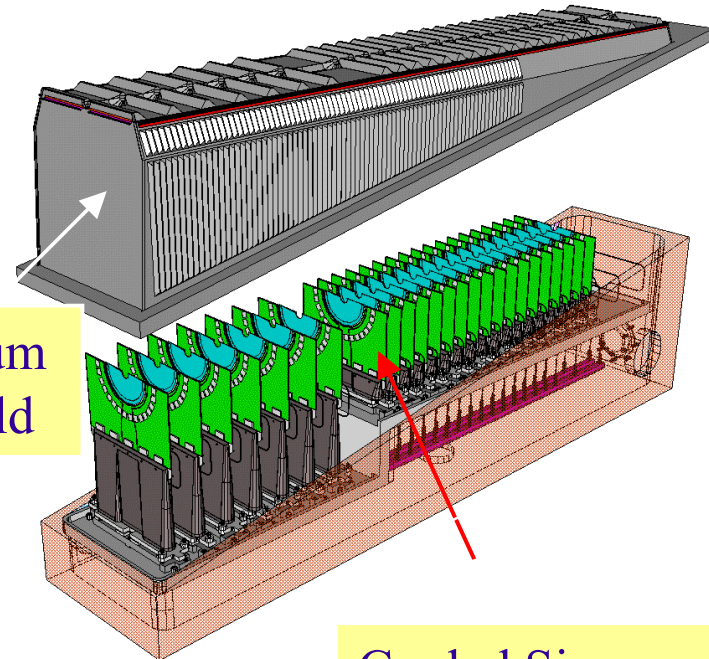

RF/Vacuum
thin shield

Exit window
1.5-2 mm
thick Al

Cooled Si sensors in
secondary vacuum

Regular reviews by the LHC machine group:

1st review: 3-4 April 2001 (very positive and constructive)

2nd review foreseen in February 2002

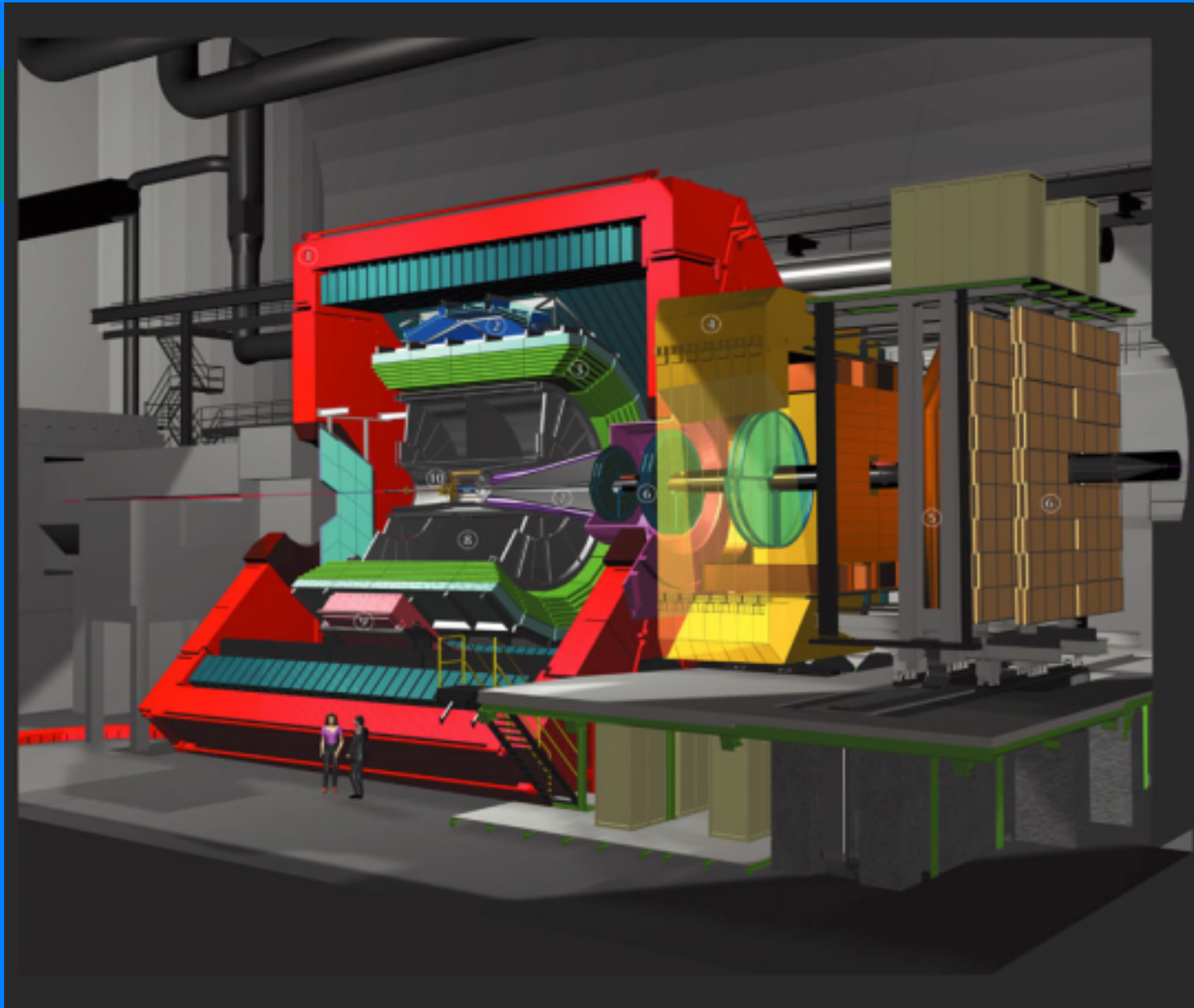

- 1• L3 MAGNET
- 2• HMPID
- 3• TOF
- 4• DIPOLE MAGNET
- 5• MUON FILTER
- 6• TRACKING CHAMBERS
- 6'• TRIGGER CHAMBERS
- 7• ABSORBER
- 8• TPC
- 9• PHOS
- 10• ITS



TOF Multigap RPC

Strip length 1.20m

2 x 48 pads

Standard unit detector for ALICE

In TOF will be ~ 1600 such strips

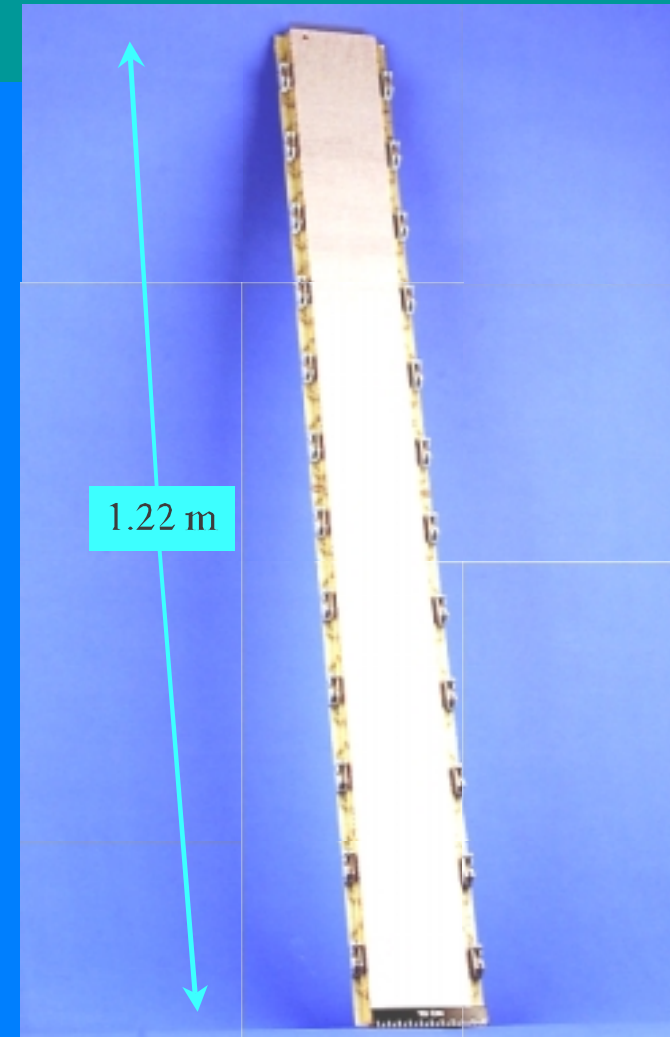
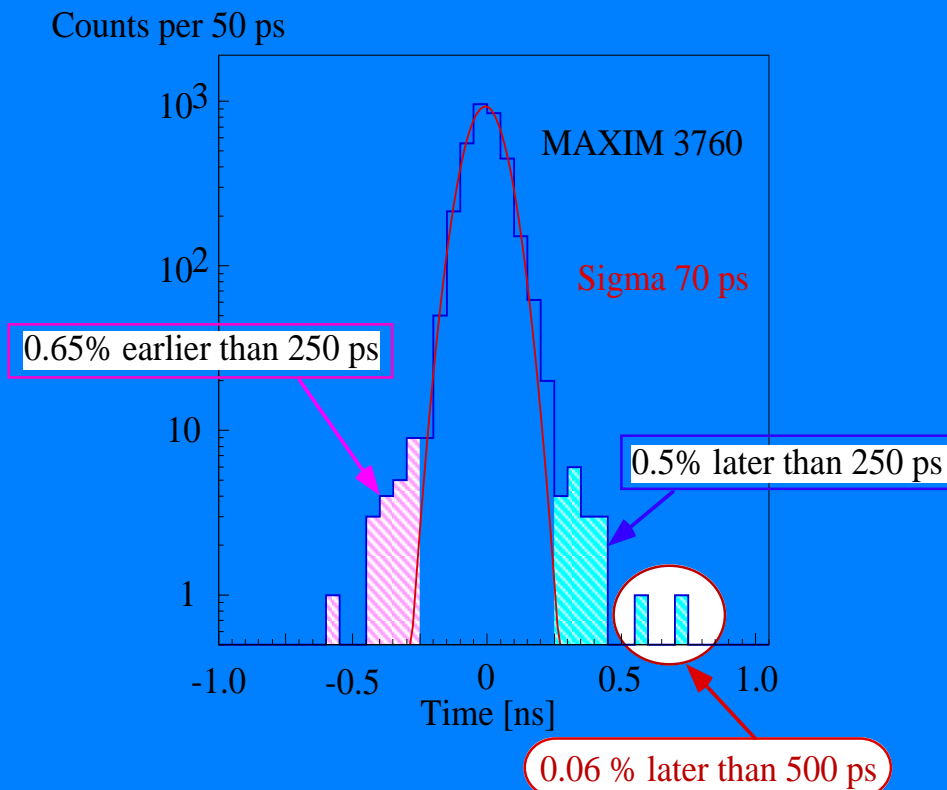

Joos Engelen, SPC, June 11, 2001

The LHC experimental programme as of 11/06/01: In general good progress

- ATLAS and CMS are learning how to go into (*mass*) production
- ALICE completing RD, starting construction; one more TDR to go: the TRD
- LHCb completing RD, starting construction; producing TDR's as foreseen

Schedule, funding

No major concerns, but:

- electronics (rad hard; front end) more difficult than anticipated
- these (in particular ATLAS and CMS) are enormous enterprises and the resources are very tight...
- still a long way to go

-
-
-

LHC

- call for tender for Cryo-dipoles assembly and for cryo-lines are out, adjudication in September/November.
- **Status Report in December 2001** will integrate the most important elements of the project:
 - most important adjudications
 - LHC computing
 - Discussion of Maintenance & Operation costs.

The LHC Computing Model

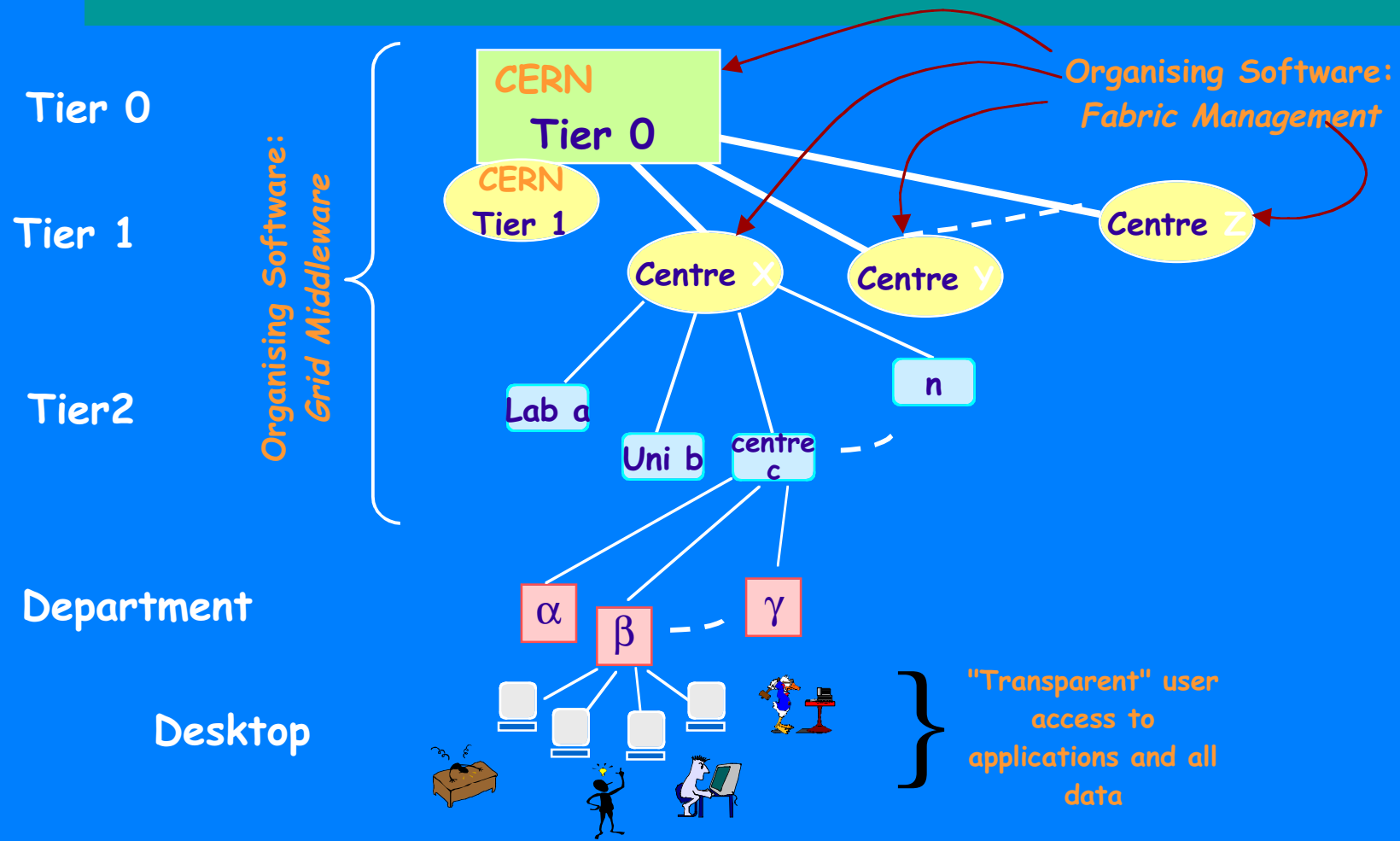

-
-
- **Complex Data = More CPU Per Byte**

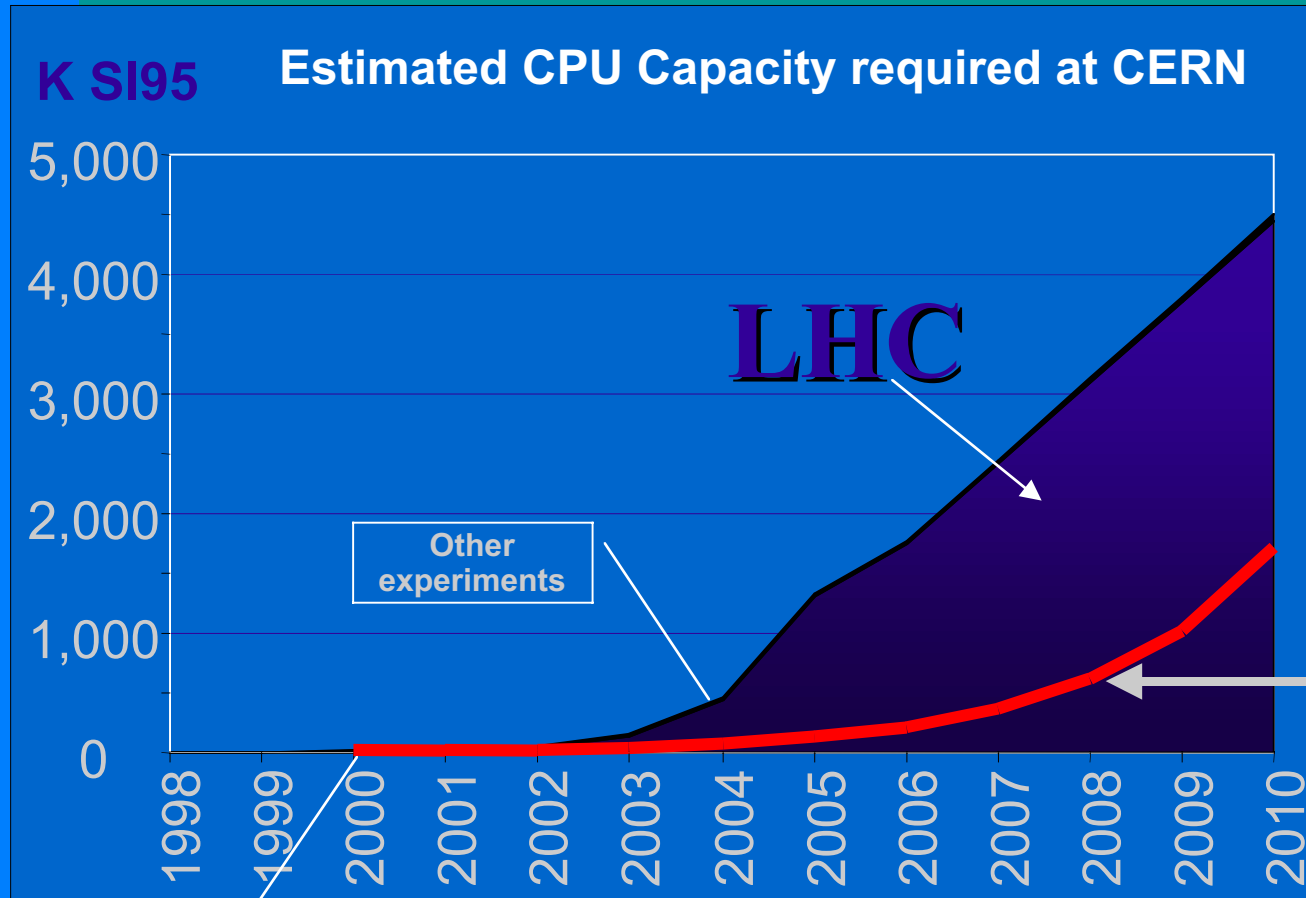

Moore's law – some measure of the capacity technology advances provide for a constant number of processors or investment



Jan 2000:
3.5K SI95

CERN Past Performance (2) : 1988-2000

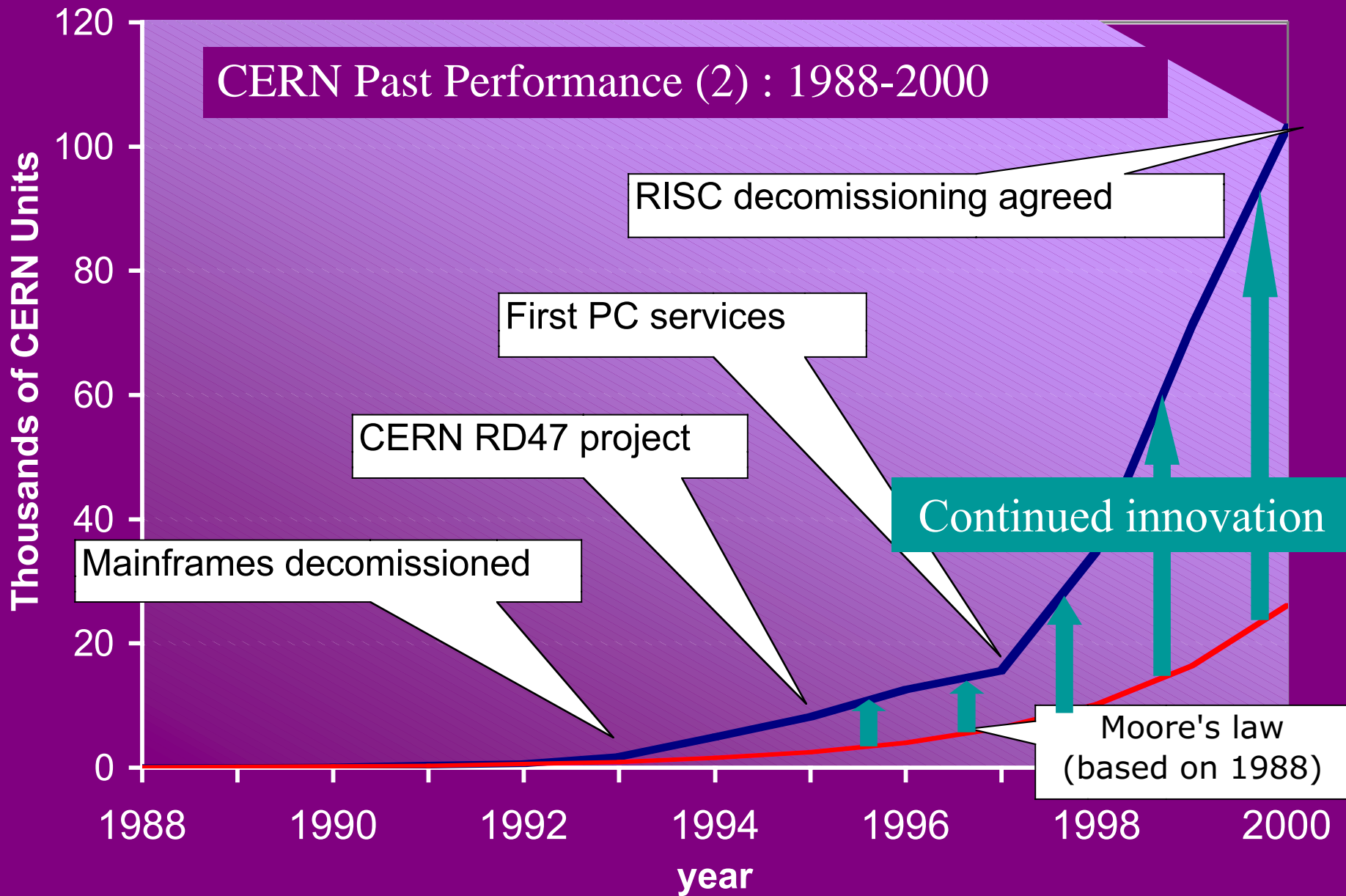

Processor farms : the 90's supercomputer

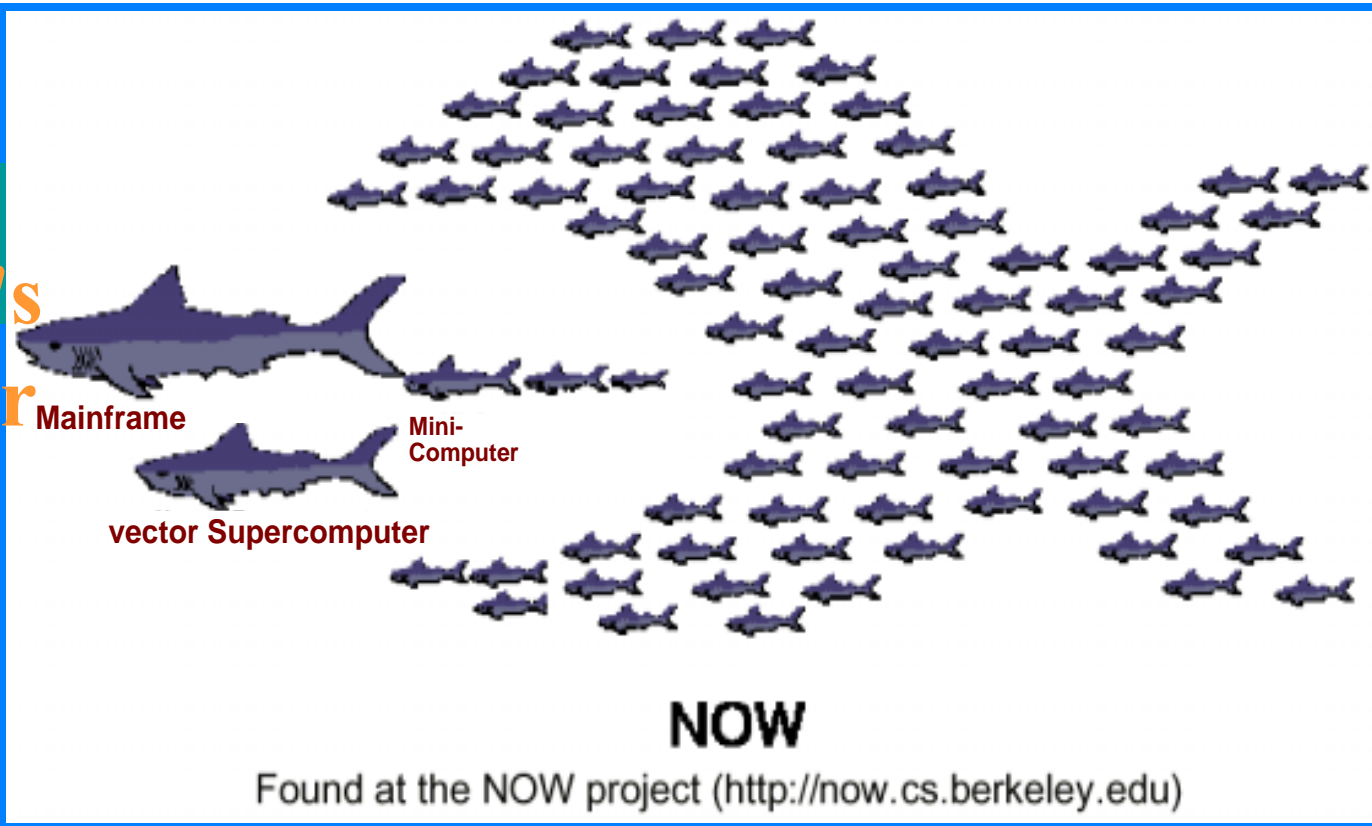

■ PC+Linux: the new supercomputer for scientific applications

obswww.unige.ch/~pfennige/gravitor/gravitor_e.html



www.cs.sandia.gov/cplant/

■ Principle well established; farm examples abound



now.cs.berkeley.edu



www.ncsa.uiuc.edu/General/CC/ntcluster/

After commodity farms what next?

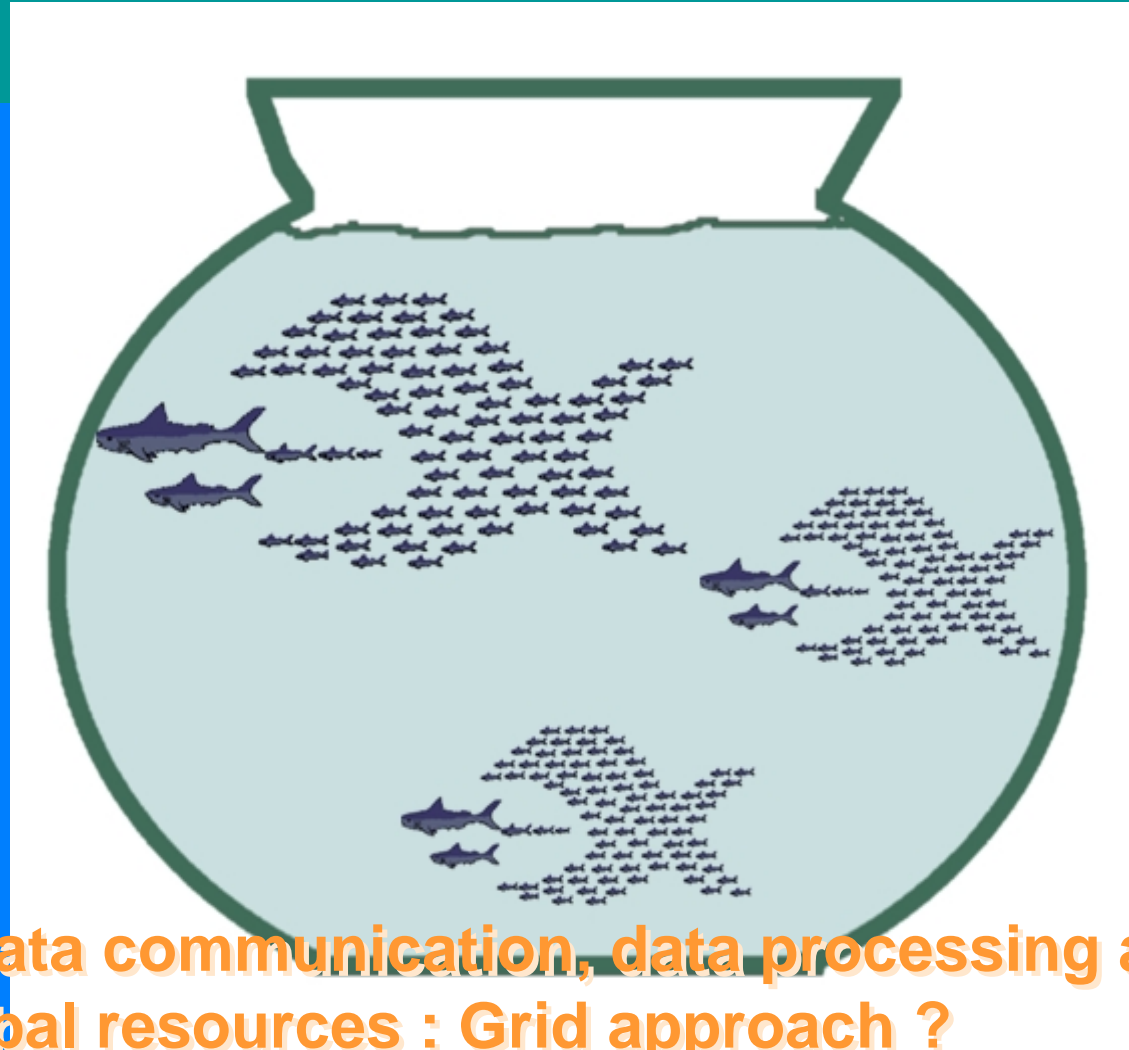

Fusion of data communication, data processing and data archive global resources : Grid approach ?

-
-
-

Outcome of CC meeting (June 14)

- Computing is part of the LHC programme
- Considerable interest in technological aspects

- Phase 1: development of a “prototype” of CERN Tier0
- Phase 2 : full Tier0, to be considered later

- Phase 1 to be funded a la carte
- If possible **decide in September on phase 1**

The LHC Computing Grid Project Structure

Version 1.3
M. Delfino
05.07.2001

DRAFT

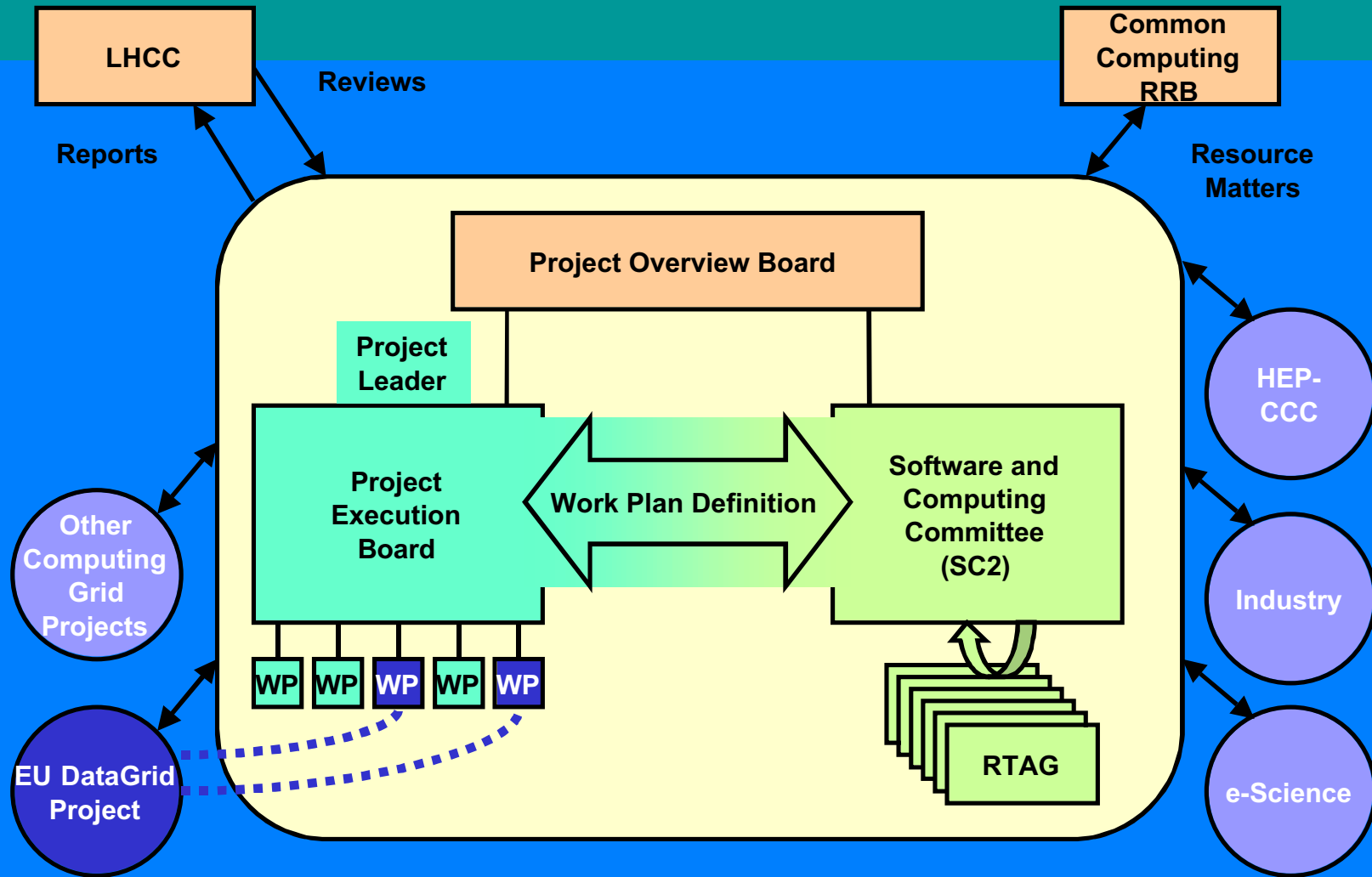

ROADMAP TOWARDS LHC DATAGRID @ CERN

Resources:

Contributions for Phase 1 pledged by:

Belgium, Finland, France, Germany, Hungary , Italy, Spain
Switzerland, UK

Austria and Portugal would utilize their Training programme

Several Countries may contribute later;

- Contributions in cash can parallel contributions in Manpower

-CERN is seeking contributions from industry.

-“Launching Committee” formed

THE PROJECT MAY START



?

RoadMap (final)

- first ideas on POB composition:
 - - Chair: Director for Scientific Computing and Technology Transfer
 - - Secretary: IT Div. Lead.
 - - Members:
 - Director for Collider Programmes
 - LHC experiments spokespersons
 - 8 representatives from Member States
 - 1 representative from each Special Observer Country (USA, Russia, Japan).
- MS representation may parallel ECFA Working Group !

Superconducting Proton Linac: layout on the CERN site

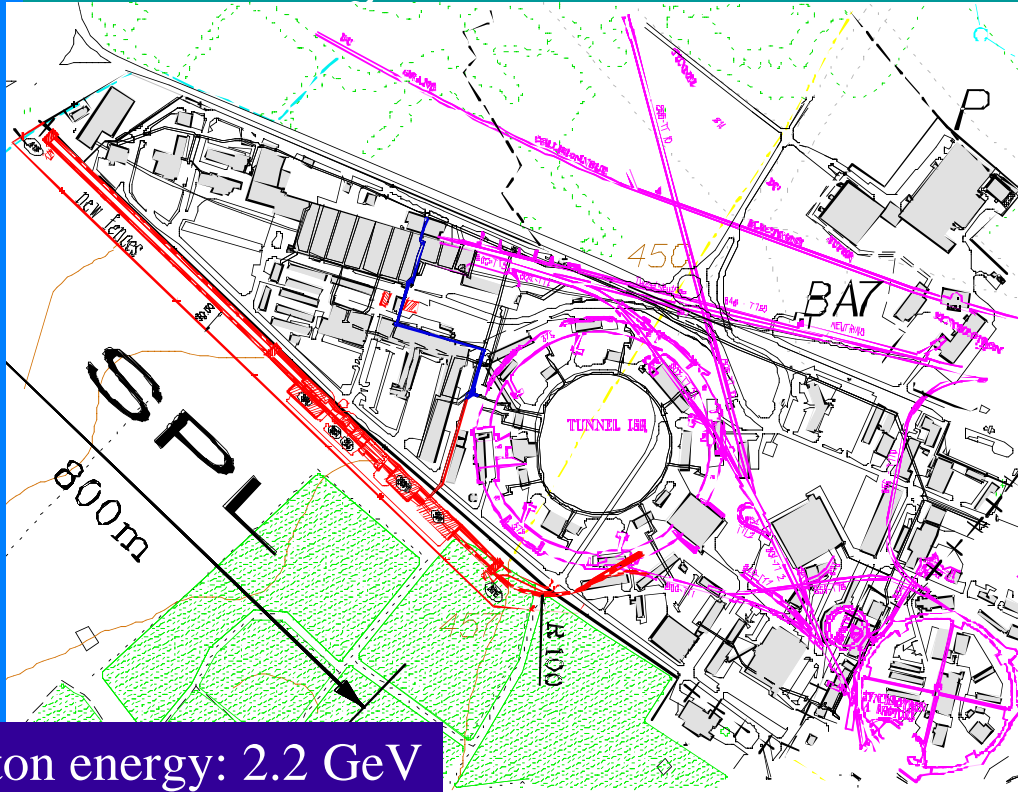

Proton energy: 2.2 GeV
Power on target: 4MW
Re-use of LEP sc cav.s
Almost pure ν_{μ} beam

Linac + klystron gallery parallel to the fence of Meyrin site (Route Gregory)

- Economic trench excavation
- Geological advantages (tunnel on "molasse", no underground water)
- Minimum impact on the environment (empty field)
- Simple connection to PS & ISR via existing tunnels
- Use some of the old ISR infrastructure (electricity, cooling)

The SC cavities for $\beta < 1$

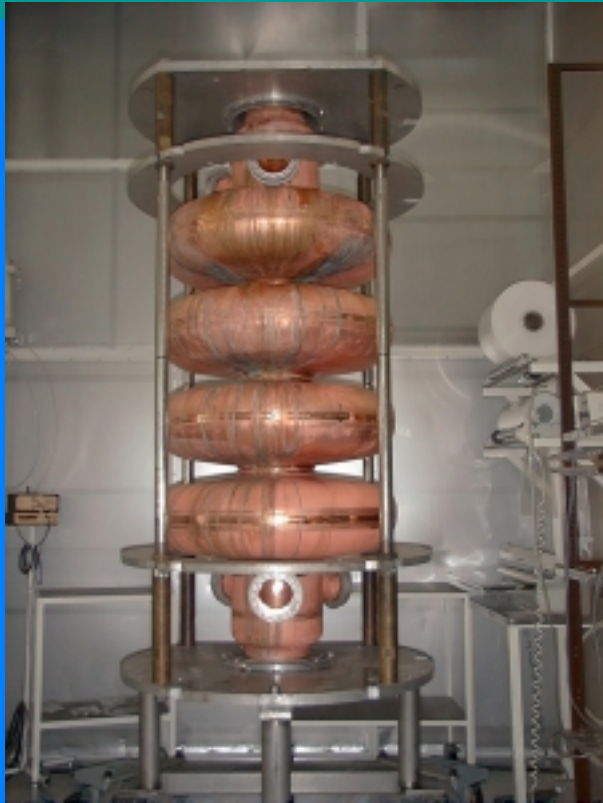

The $\beta=0.7$ 4-cell prototype

☆ CERN technique of Nb/Cu sputtering for $\beta=0.7$, $\beta=0.8$ cavities (352 MHz):

- lower material cost, large apertures, released tolerances, 4.5 °K operation with $Q = 10^9$

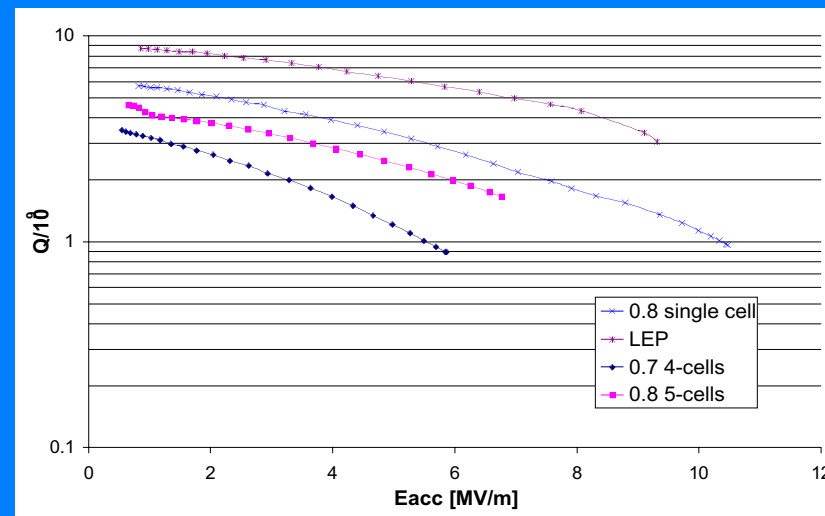

☆ Bulk Nb or mixed technique for $\beta=0.52$ (one 100 kW tetrode per cavity)

-
-
-

to a very long distance
Laboratory($\approx 3000\text{km}$)

to Gran Sasso,
730 km

CERN design of a Neutrino Factory

4MW on target

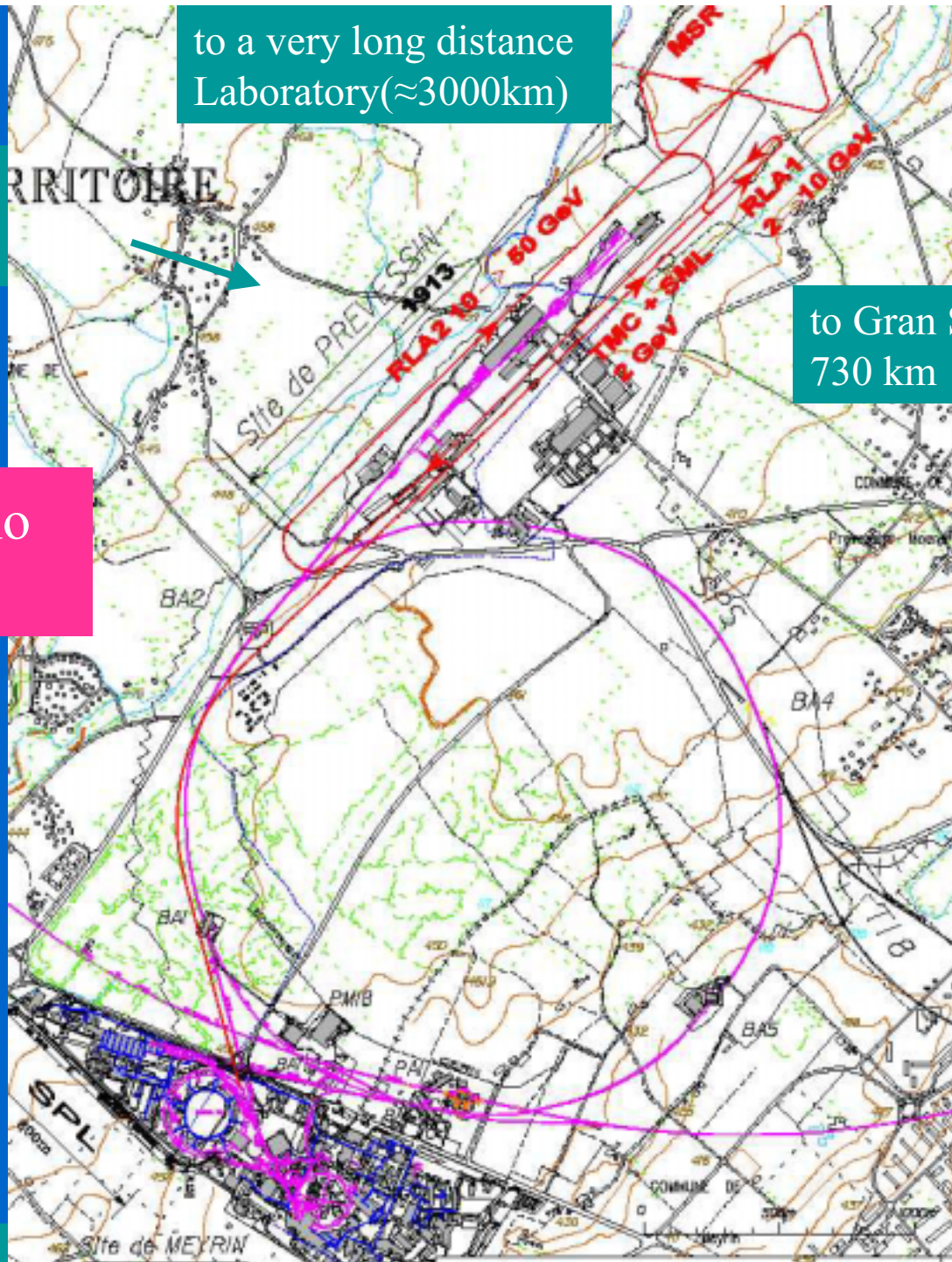

Search for long-baseline detector laboratories

Best long baseline is around 3000km
for CP violation + matter effects.

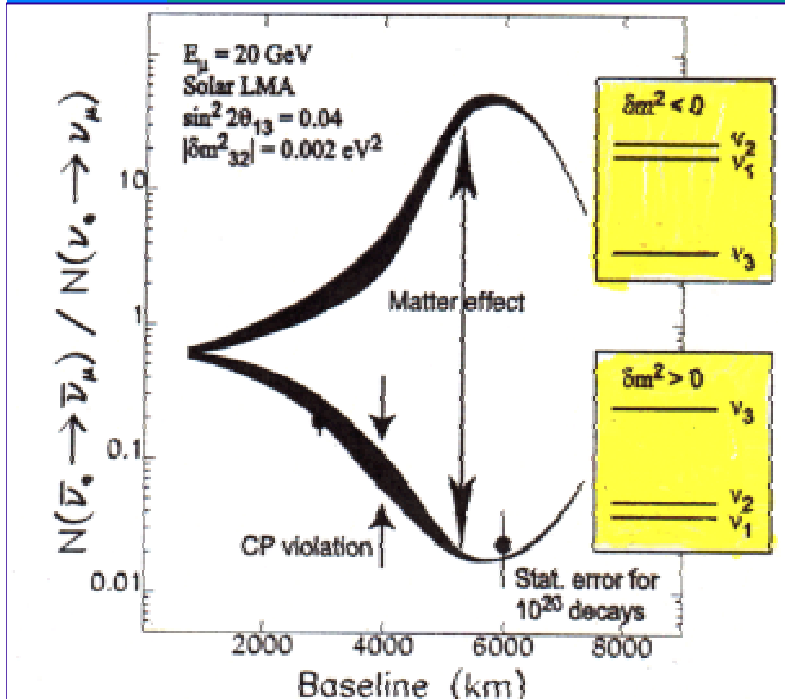

search for possible underground sites (H. Wenninger et al)

Gran Canaria (Spain); Spitzbergen (Svalbard, Norway);
Center for underground physics Pihäsalmi (Finland)

P. Gruber

CLIC Test Facility 3

Two beam acceleration

$150 \text{ MeV/m} = 1.5 \text{ TeV/10km}$

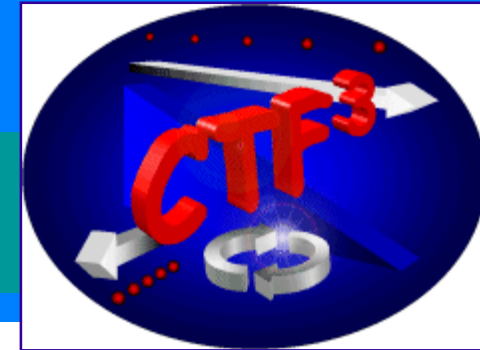

Layout of CFT3 Nominal Phase

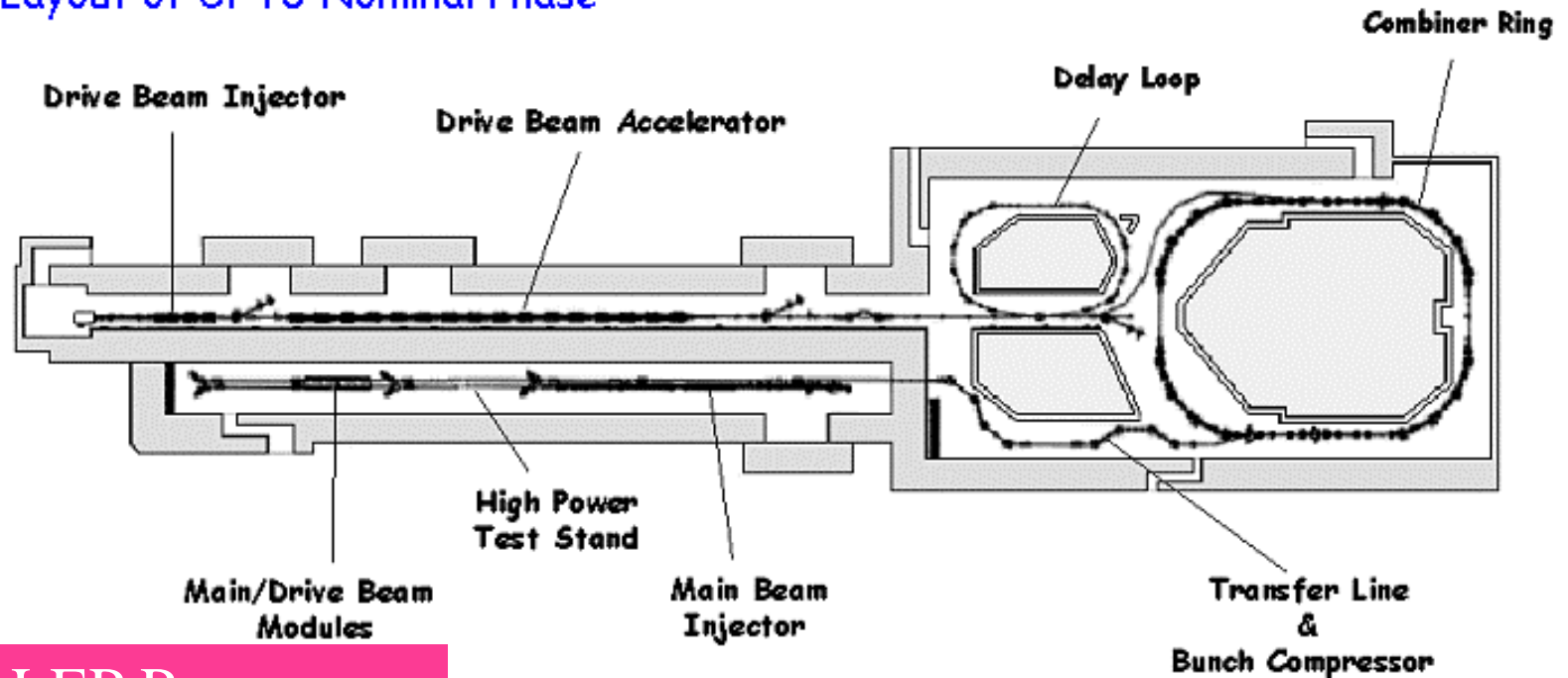

Housed in LEP Pre-Injector building
Construction 2001-2003

Overall Layout of the CLIC complex at $E_{\text{tot}} = 3 \text{ TeV}$

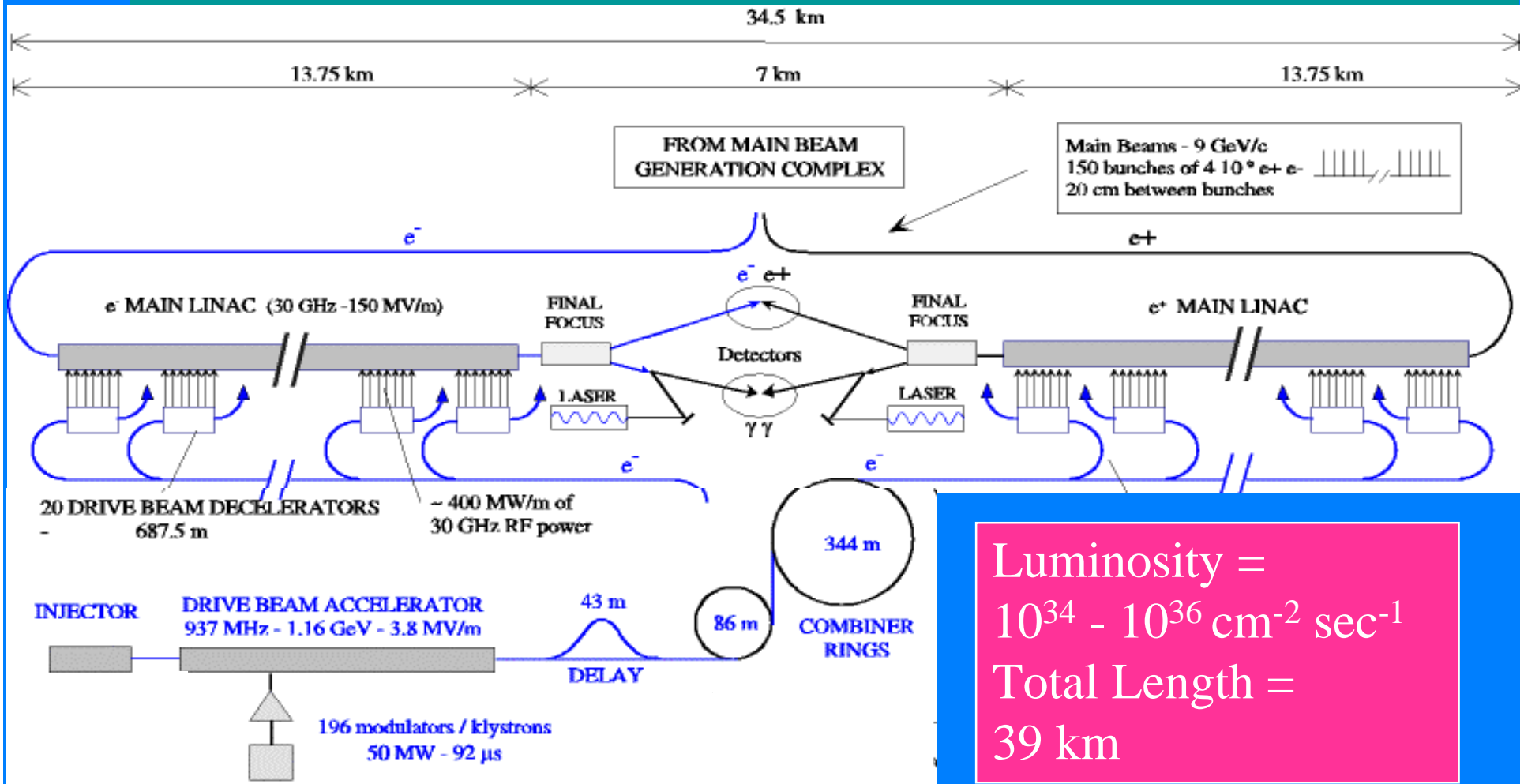

-
-
-

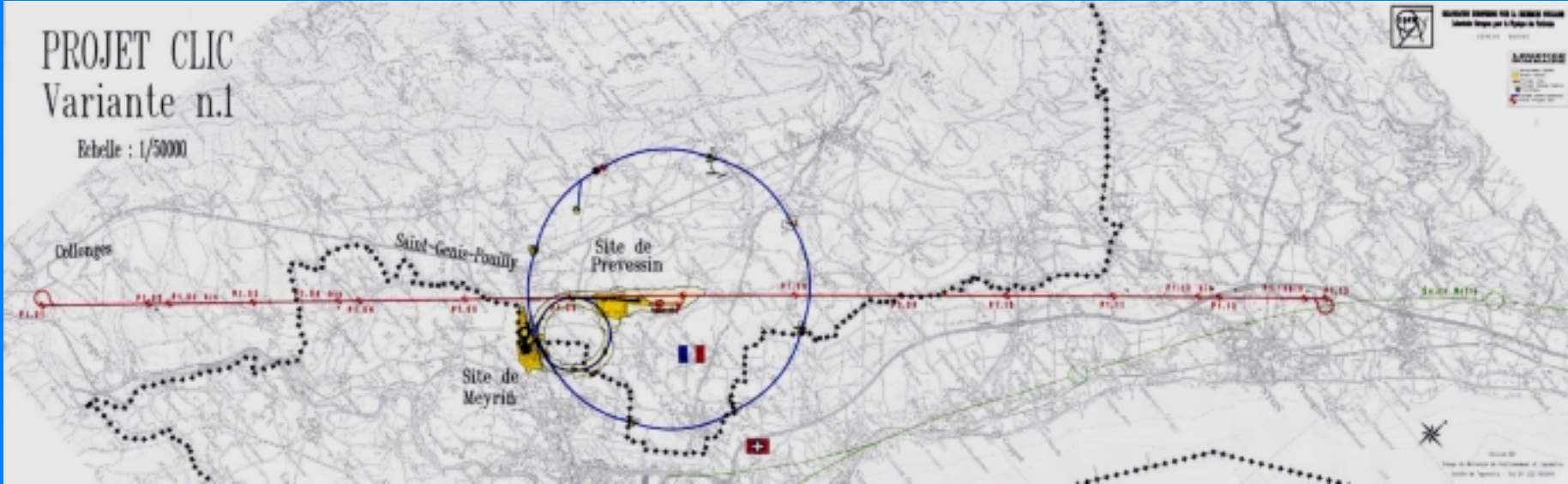

Fitting CLIC at CERN



-
-
-
-
-
-
-
-
-



Projet 240 km - Variantes Est et Ouest

VLHC at CERN?
(Circ. = 240 Km)

SITUATION



Pr. J.C. Fourneaux

L. Maiani, 3/09/2000

Plenary ECFA

Exploratory study
shows prohibitive tunnel cost

•
•
•

Summing up...

- Direct CP violation established at CERN&FermiLab
- Hints of a Higgs boson at 115 GeV persist !
- Thinking about the future: nu-superbeams/factory, MultiTeV e+e- collider (CLIC under study)
- LHC computing: Tier0 prototype (Phase 1) on track
- LHC construction is progressing regularly: civil works, magnets, detectors...

1721 days to April 1, 2006

LEP working group for Higgs boson searches, July 10, 2001 (cont'd)

If accumulating signal + background ...

July 10, 2001

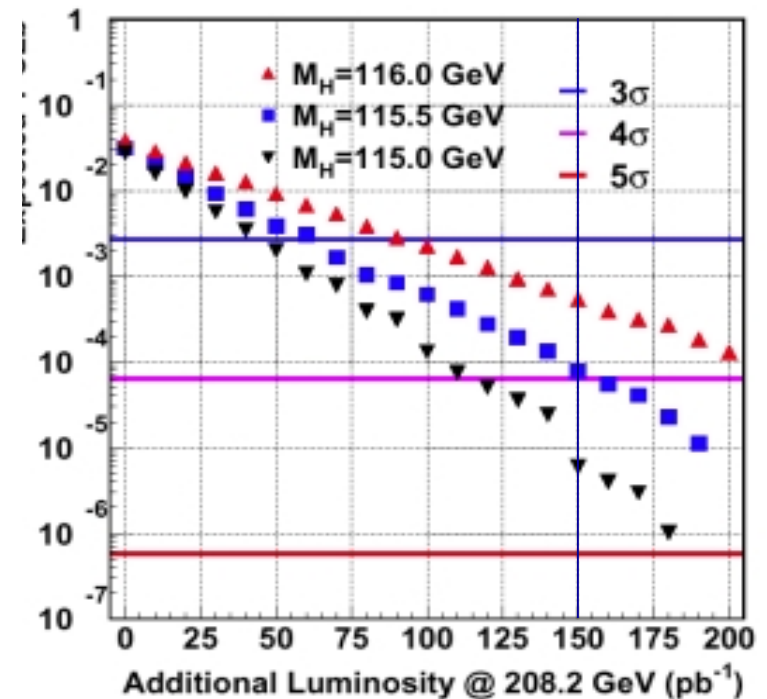
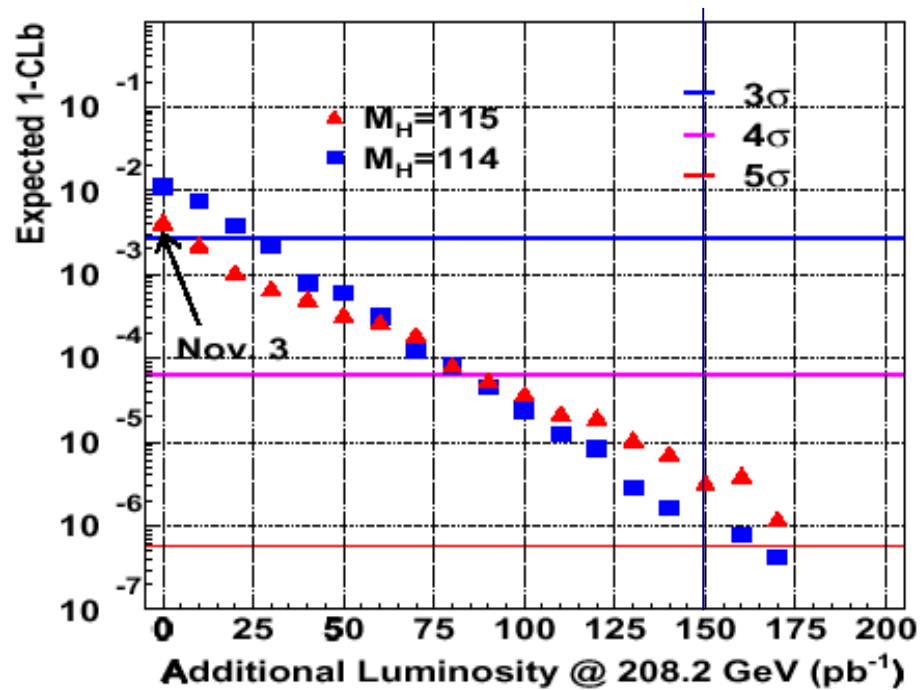

P. Igo-Kemenes - LEP Seminar - Nov. 3, 2000

CERN commitments and payments

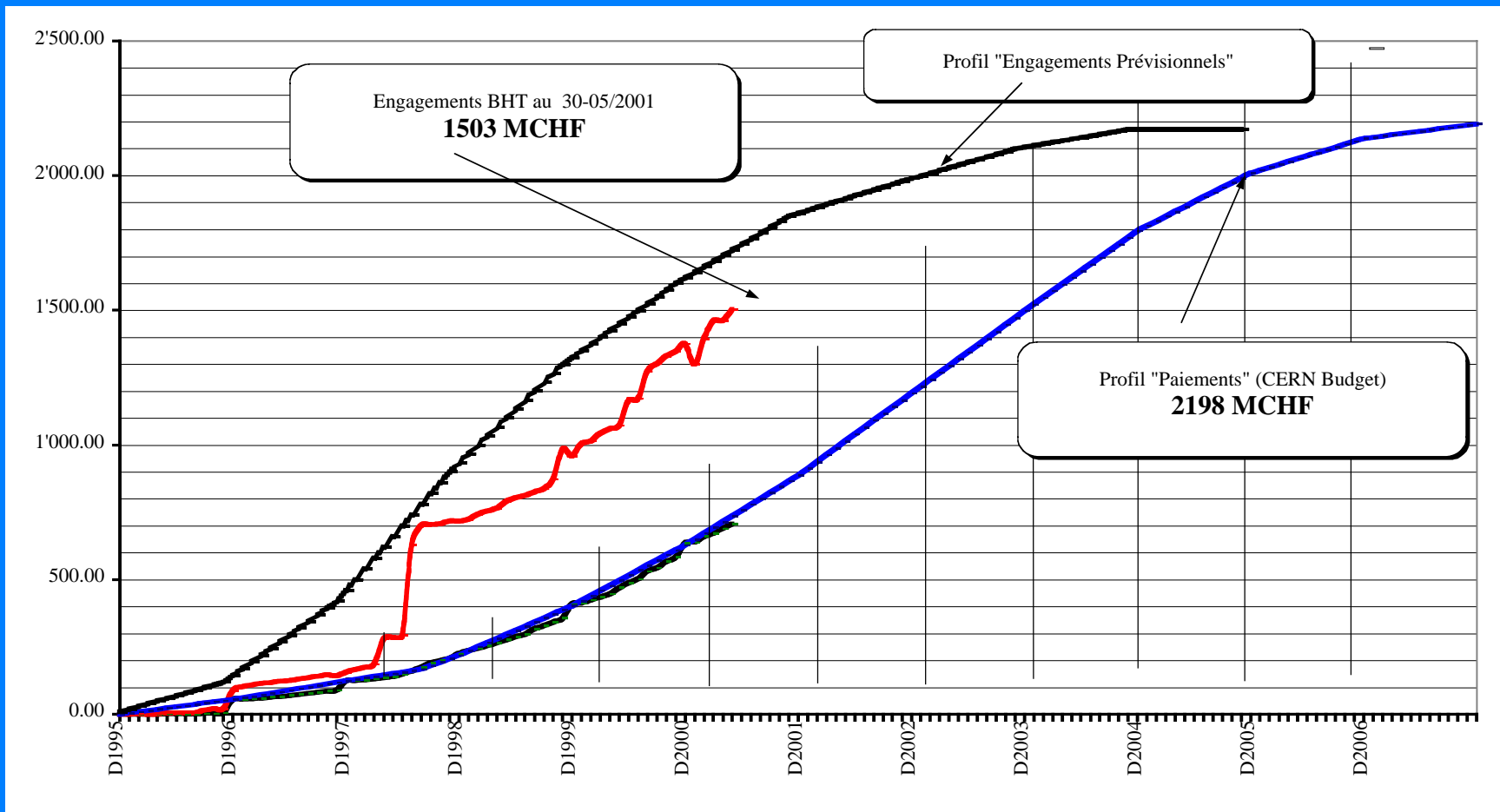

LHC commissioning schedule

