

The EXPLORER gravitational wave antenna: recent improvements and performances

P Astone¹, M Bassan^{2,3}, P Bonifazi^{1,4}, P Carelli^{3,5}, M G Castellano^{3,6},
G Cavallari⁷, E Coccia^{2,3}, C Cosmelli^{1,8}, S D'Antonio⁹, V Fafone⁹,
G Federici¹, Y Minenkov³, G Modestino⁹, I Modena^{2,3}, A Moleti^{2,3},
G Pizzella^{2,9}, G V Pallottino^{1,8}, L Quintieri⁹, A Rocchi², F Ronga⁹,
R Terenzi^{3,4}, G Torrioli^{3,6} and M Visco^{3,4}

¹ INFN, Sezione di Roma 1, Piazzale A Moro 2, Roma, Italy

² Dip. Fisica, Università di Roma 'Tor Vergata', V. le della Ricerca Scientifica, Roma, Italy

³ INFN, Sezione di Roma 2, V. le della Ricerca Scientifica, Roma, Italy

⁴ CNR, Istituto Fisica Spazio Interplanetario, Via Fosso del Cavaliere, Roma, Italy

⁵ Dipartimento di Energetica, Università dell'Aquila, Roio Poggio, Italy

⁶ CNR, Istituto di Fisica dello Stato Solido, Via Cineto Romano 42, Roma, Italy

⁷ CERN, Geneva, Switzerland

⁸ Dipartimento Fisica, Università di Roma 'La Sapienza', Piazzale A Moro 2, Roma, Italy

⁹ INFN, Laboratori Nazionali di Frascati, Via Enrico Fermi, Frascati, Italy

E-mail: massimo.visco@ifsi.rm.cnr.it

Received 31 October 2001, in final form 13 December 2001

Published 18 March 2002

Online at stacks.iop.org/CQG/19/1905

Abstract

Since the beginning of 2000 the EXPLORER gravity wave (GW) detector has been operated continuously after a stop devoted to improve the apparatus. The antenna has been equipped with a new read-out. The use of a new transducer, characterized by a very small gap, and a dc-SQUID with a high coupling, led to a better sensitivity and a larger bandwidth. The EXPLORER sensitivity in terms of spectral noise amplitude, at present (June 2001), is 10^{-20} Hz^{-1/2} over a bandwidth of 35 Hz and 3×10^{-21} Hz^{-1/2} with a bandwidth of about 6 Hz, corresponding to a sensitivity to short conventional GW bursts of $h = 4 \times 10^{-19}$. The performance is stable and the apparatus is taking data with a duty cycle in excess of 80%.

PACS numbers: 0480N, 9555Y

1. Introduction

EXPLORER [1], installed at CERN Laboratories in Geneva, is one of the two resonant gravitational antennas of the Rome group. It has been in operation since 1984 and it has performed long-term observations since 1990 (see figure 1). The data acquired during its

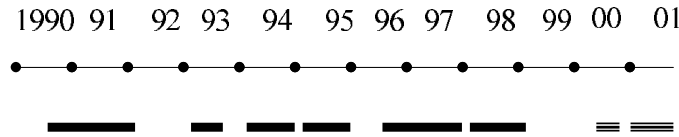

Figure 1. Operation during the past 10 years. During 1999, the experimental apparatus was upgraded.

long activity were used to calculate different upper limits both for pulse signals [1–5] and for stochastic background [6, 7].

EXPLORER is a part of the international network of resonant-mass detectors (IGEC Collaboration) [5] which includes ALLEGRO at the Louisiana State University, AURIGA at the INFN Legnaro Laboratories, NAUTILUS at the INFN Frascati Laboratories and NIOBE at the University of Western Australia.

During 1999, we modified the detection apparatus of EXPLORER to improve its sensitivity and its immunity from external seismic noise. Since the beginning of 2000 it has started to gather data again. The performance is stable and the periods with data of good quality are at the moment (June 2001) more than 80% of the total time. The remaining periods are mostly lost due to the periodic cryogenics operations.

2. Sensitivity of the detector

In a gravitational wave (GW) detector, two unavoidable sources of noise limit the sensitivity: the thermal noise associated with dissipation in the antenna and the electronic noise of the amplifier.

The first source of noise can be reduced by cooling the antenna. Several efforts were made in recent years in this direction and nowadays, as a result, some detectors [8, 9] cooled at thermodynamic temperature close to 100 mK are in continuous operation.

The reduction of the amplifier noise influence was equally faced. The use of dc-SQUID has permitted the contribution of the electronic noise to be strongly decreased, but there are still opportunities to make significant progress in improving the electromechanical transducer and its coupling to the SQUID.

The sensitivity of a resonant bar can be conveniently expressed by means of the noise S_h referred to the input of the detector as if it were a GW spectral density. The shape of S_h is strongly peaked around the frequencies of the two modes where the lowest values S_h^{\min} are reached. S_h^{\min} does not depend, in a first approximation, on the electronic noise, but only on physical parameters of the antenna (length L , mass M , resonant frequency ω_0), on the thermodynamic temperature T and on the mechanical quality factor Q :

$$S_h^{\min} \propto \frac{T}{QML\omega_0^3}. \quad (1)$$

S_h^{\min} gives the maximum sensitivity for monochromatic or stochastic sources.

If short pulses of GWs are considered, the sensitivity can be calculated integrating $S_h(\omega)$ over the spectrum and the performances of a detector can be conveniently expressed by means of the minimum modification of the metric tensor h detectable by the apparatus. The sensitivity to burst depends not only on the minimum value of S_h , but also on the bandwidth.

The bandwidth $\Delta\omega_0$ of the detector is strongly affected by the electronic noise of the apparatus:

$$\Delta\omega_0 = \frac{\omega_0}{Q\sqrt{\Gamma}} \quad \text{where} \quad \Gamma \approx \frac{T_n}{2\beta QT}. \quad (2)$$

T_n is the noise temperature of the amplifier used, β is a factor representing the coupling between the mechanical and electrical parts of the system and depends on the transducer and its matching to the amplifier used. Γ gives the ratio between the wide-band noise in the resonance bandwidth and the narrow-band noise.

The physical parameters of the antenna (M, L, ω_0) and the thermodynamic temperature T are fixed in a given detector, so the most significant improvements of a bar detector sensitivity can be achieved by decreasing the contribution of the electronic noise T_n and increasing the coupling β of the transducer to the SQUID.

The groups involved in resonant detectors, during the last several years, have devoted substantial efforts in this direction and the first significant results have appeared.

3. Experimental configuration

The antenna is made of high Q alloy Al 5056, has a mass $M = 2200$ kg and a resonant frequency around 900 Hz. It can be cooled in a cryostat by superfluid liquid helium at a temperature around 2.5 K.

The antenna is equipped with a capacitive resonant transducer and uses a superconductive interferometer dc-SQUID as amplifier (see figure 2).

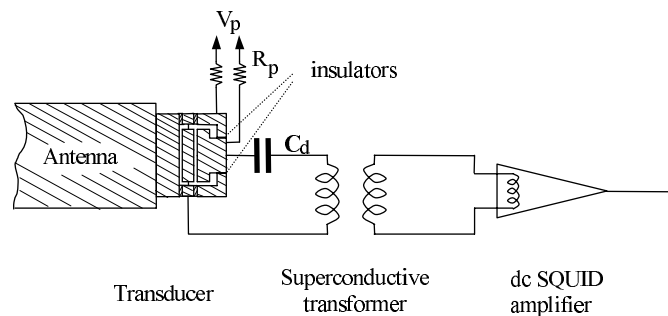

Figure 2. Read-out scheme.

The transducer, developed by our group [12], has an innovative design. It has been used for the first time on this detector since the beginning of 2000. The peculiar geometry of the resonator, ‘rosette’ shaped, allows a gap as small as $10 \mu\text{m}$ and consequently a capacitance $C_t = 12$ nF that is more than three times larger than in the transducers we used in the past. Its mechanical Q is about 2×10^6 and the overall Q expected for the system is around 5×10^6 . The dc-SQUID is a commercial device produced by Quantum Design, it has an input flux noise Φ_n comparable to that measured with the SQUID previously used, but its input coil mutual inductance $M_s = 10$ nH provides a coupling three times larger than in the past.

The use of this new transducer and SQUID has increased the coupling between the mechanical and electrical parts of the circuit, decreasing the Γ by a factor larger than 100.

With this configuration, we expected a spectral sensitivity $\sqrt{S_h}$ such as the dashed line in figure 3 [11] with a bandwidth larger than 10 Hz, corresponding to a minimum detectable $h \sim 2 \times 10^{-19}$ for conventional standard pulses.

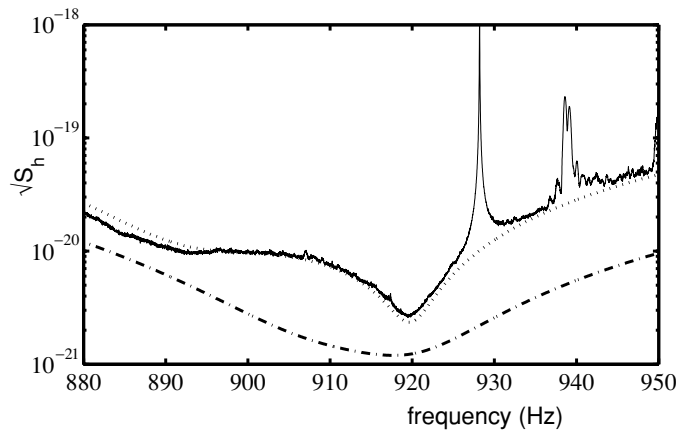

Figure 3. $\sqrt{S_h}$ over 10 h of data.

4. Results and perspectives

The EXPLORER new run started at the beginning of the year 2000 but only starting from the end of November were we able to get a set-up that assures reliable operations and very good and stable performances.

The data at the SQUID output are sampled at 5 kHz and filtered with an adaptive matched filter. Figure 3 shows a typical plot of the $S_h(\omega)$ relative to 10 h of data, whereas the dotted line represents the sensitivity predicted by a numerical model of the detector [11]. The frequencies of the two modes of oscillation of the antenna–transducer system, with a biasing field $E = 7.3 \text{ MV m}^{-1}$, are $\nu_- = 888.66 \text{ Hz}$ and $\nu_+ = 919.82 \text{ Hz}$. The mechanical quality factors are respectively $Q_- = 6 \times 10^4$ and $Q_+ = 2 \times 10^5$. During these measurements the dc-SQUID exhibited a flux noise of $12 \mu\Phi_0 \text{ Hz}^{-1/2}$.

The EXPLORER sensitivity in terms of spectral noise amplitude, at present (June 2001), is $10^{-20} \text{ Hz}^{-1/2}$ over a bandwidth of 35 Hz and $3 \times 10^{-21} \text{ Hz}^{-1/2}$ with a bandwidth of about 6 Hz, corresponding to a sensitivity to conventional GW bursts of $h = 4 \times 10^{-19}$.

The values of the mechanical quality factor are lower and the noise of the SQUID is higher than expected. Therefore, the sensitivity does not match that expected (dashed line in figure 3) with all the parts of the apparatus working at their best. We are confident that we will be able to obtain these results in the near future as all the operations required to possibly obtain the goals can be performed without warming up the apparatus.

In figure 4 we report, for the period February–June 2001, the value of h averaged every half an hour. For most of the time its value is $4\text{--}5 \times 10^{-19}$. The duty cycle in this period is larger than 80% of the total time.

In figure 5 we show a histogram of h values over an entire day of good operation: the distribution is well fitted by a Gaussian with standard deviation equal to 4×10^{-19} , although a small tail of a few tens of samples is present.

The sensitivity expected with the present experimental configuration is not the ultimate reachable by EXPLORER: the use of an amplifier made with a double SQUID, a new transducer with a higher capacitance and a superconductive transformer with lower dissipation, will lead us to increase the sensitivity enough to detect $h \sim 3 \times 10^{-20}$. The future detection apparatus is under test in our lab and could be used for the next improvement of EXPLORER antenna.

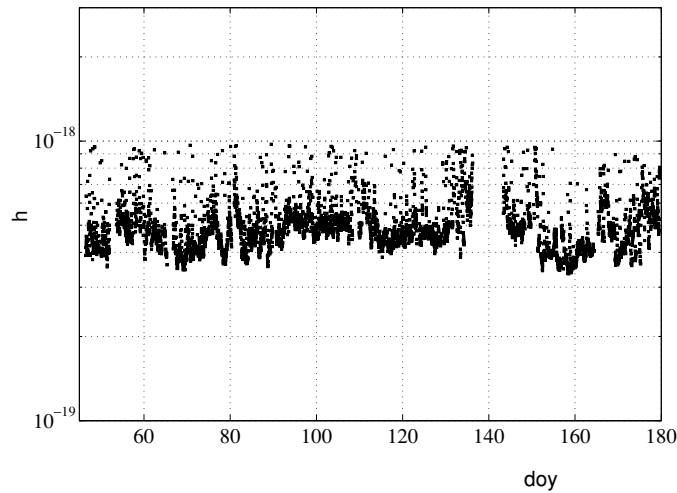

Figure 4. Operation from January to June 2001—30 min averaged data.

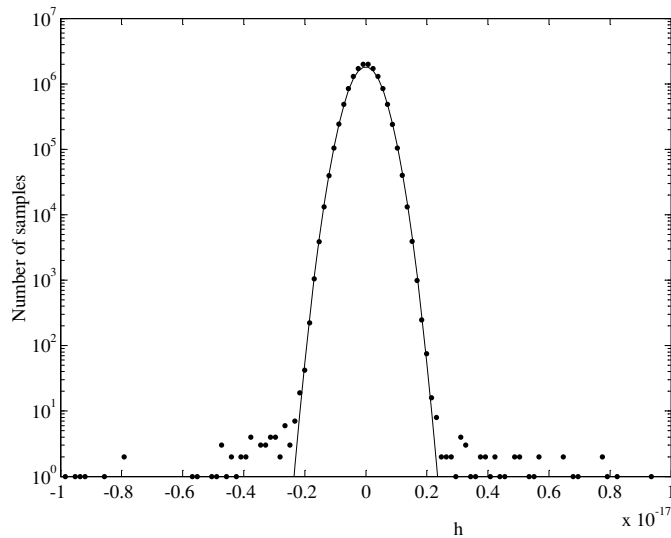

Figure 5. Distribution of 24 h of EXPLORER data—day 161 of 2001.

Next year, similar to NAUTILUS [10], the apparatus will be equipped with a cosmic ray detector consisting of plastic scintillators, one layer of 6 m^2 under the cryostat and two layers of 13 m^2 above it. This improvement will make it possible to study signals induced in the antenna by cosmic rays crossing it.

Conversely, the experience gained with the new read-out of EXPLORER will be used for the next upgrade of the NAUTILUS antenna, foreseen in early 2002.

Acknowledgments

We thank F Campolungo, R Lenci, G Martinelli, E Serrani, R Simonetti and F Tabacchioni for their valuable technical support.

References

- [1] Astone P *et al* 1993 *Phys. Rev. D* **47** 362
- [2] Amaldi E *et al* 1989 *Astron. Astrophys.* **216** 325
- [3] Amaldi E *et al* 1990 *Europhys. Lett.* **12** 5
- [4] Astone P *et al* 1999 *Phys. Rev. D* **59** 122001
- [5] Allen Z *et al* 2000 *Phys. Rev. Lett.* **85** 5046
- [6] Astone P *et al* 1996 *Phys. Lett. B* **385** 421
- [7] Astone P *et al* 1999 *Astron. Astrophys.* **351** 811
- [8] Astone P *et al* 1997 *Astropart. Phys.* **7** 231
- [9] Prodi G A *et al* 1998 Initial operation of the gravitational wave detector AURIGA 2nd Edoardo Amaldi Conf. on Gravitational Wave Experiments (Geneva, Switzerland, 1997) ed E Coccia, G Veneziano and G Pizzella (Singapore: World Scientific) pp 148–58
- [10] Astone P *et al* 2000 *Phys. Rev. Lett.* **84** 14
- [11] Bassan M The GASP numerical model for resonant antennas (unpublished)
- [12] Bassan M, Minenkov Y and Simonetti R 1997 Advances in linear transducers for resonant gravitational wave antennas *Proc. Virgo Conf. on Gravitational Waves: Sources and Detectors (Cascina, Mar. 1996)* ed I Ciufolini and F Fiducaro (Singapore: World Scientific) pp 225–8